



	page
Contents	i
CHAPTER 1	
INTRODUCTION	1
General Description	1
532 Auto/Manual Backup Station	1
Confirming What Is Included	2
Where to Begin	2
Overview of the 532 Modes	2
Where To Go Next	2
Order Codes	3
CHAPTER 2	
BASIC OPERATION	4
532 Operator Interface	4
Displays	4
Icons	5
Keys	5
532 Operating Procedures	6
532 Alarm Operation	7
Alarm Indication	7
Alarm Acknowledgment	7
Latching Alarms	8
Limit Sequence	8
More on Alarms	8
CHAPTER 3	
HARDWARE SET UP	9
Hardware Settings	9
A. Process Variable Indicator Type	10
B. Mechanical Relays	11
Hardware Adjustments	11
A. Accessing and Changing Jumpers	11
B. Adding or Changing Output Modules	12
CHAPTER 4	
INSTALLATION & WIRING	15
System Planning	15
A. Consider the Noise Factor	15
B. Wiring Practice Resources	15
Installation	15
A. Make the panel cutout	15
B. Establish a waterproof seal	16
C. Mount station into panel	16
Input Wiring for the 532	17
A. AC Power	17
B. Process Variable Indicator	18
C. Digital Inputs	19
D. Setpoint or Valve Position Indicator	19
Output Wiring for the 532	20
A. CV Output	20
B. Mechanical Relay Output	20
C. Solid State Relay (Triac) Output	20
D. DC Logic (SSR Drive) Output	20

About This Manual:

For your safety and information, when using this Manual we have highlighted **NOTES**, **CAUTIONS** and **WARNINGS**. Please heed these safety and good practice notices for the protection of you and your equipment.

Contents

	page
Wiring the Serial Communications Option	21
Where to Go Next	21
CHAPTER 5	
SOFTWARE SET UP	22
Mode Overview	22
Menus	22
Smart Menus	22
Set Up Procedures	23
Step-by-Step Guide to Software Set Up	24
CONFIG.	24
LOCAL OUT.	25
PV INPUT	26
CUST. LINR.	27
SP INPUT	28
VP INPUT	29
ALARMS	29
SECURITY	33
SER. COMM.	33
OPERATION	34
Software Set Up Charts	36
CHAPTER 6	
APPLICATIONS	41
532 Auto/Manual Station	41
Alarm Set Up	42
A. Set the Alarm Type	42
B. Set the Alarm Parameters	43
Digital Inputs	47
PV, SP and VP Indication	48
A. Choose the Type of Display(s)	48
B. Select the Process Variable Display Range	48
C. Set Point Display Range	49
D. Valve Position Display Range	49
Input Linearization	49
A. Thermocouple and RTD Linearization	49
B. Square Root Linearization	50
C. Custom Linearization	50
Ramp to Control Value	52
Security	52
Process Variable Reading Correction	53
Serial Communications	54
APPENDIX A	
MENU & PARAMETER FLOWCHARTS	A-1
APPENDIX B	
PARTS LIST	B-1
APPENDIX C	
TROUBLESHOOTING	C-1
APPENDIX D	
CALIBRATION	D-1

	page
Regarding Calibration	D-1
RTD, VmA Input Calibration	D-2
Thermocouple & Cold Junction Calibration	D-3
Milliamp Output Calibration	D-4
Hardware Scan	D-6
APPENDIX E	
SPECIFICATIONS	E-1

Contents

Figure	Title	Page
2.1	532 Operator Interface	4
2.2	Before and After Acknowledging an Alarm	8
3.1	Location of Printed Circuit Boards	9
3.2	The Microcontroller Circuit Board	10
3.3	The Option Circuit Board	10
3.4	The Power Supply Circuit Board	10
3.5	Representation of Module (view of bottom)	13
4.1	532 instrument panel and cutout dimensions	15
4.2	Mounting Brackets	16
4.3	532 Rear Terminals	17
4.4	Output Wiring for the 532	20
4.5	Serial Communications Terminals	21
5.1	Menu Flowchart for Set Up	22
5.2	Independent Parameters versus Dependent Parameters	23
5.3	Keys to Enter and Move through Set Up Mode	23
6.1	Alarm Examples	46
6.2	Square Root Linearization Formula	50
6.3	Custom Linearization Curve	51
D.1	Flowchart to Access the Calibration Menus	D-1
D.2	Microcontroller Circuit Board	D-2
D.3	RTD, VmA Calibration Wiring	D-3
D.4	Thermocouple & Cold Junction Calibration Wiring	D-3
D.5	Milliamp Calibration Wiring	D-5
D.6	Flowchart for Access to Reset and Hardware Scan Menus	D-6

CHAPTER 1

INTRODUCTION

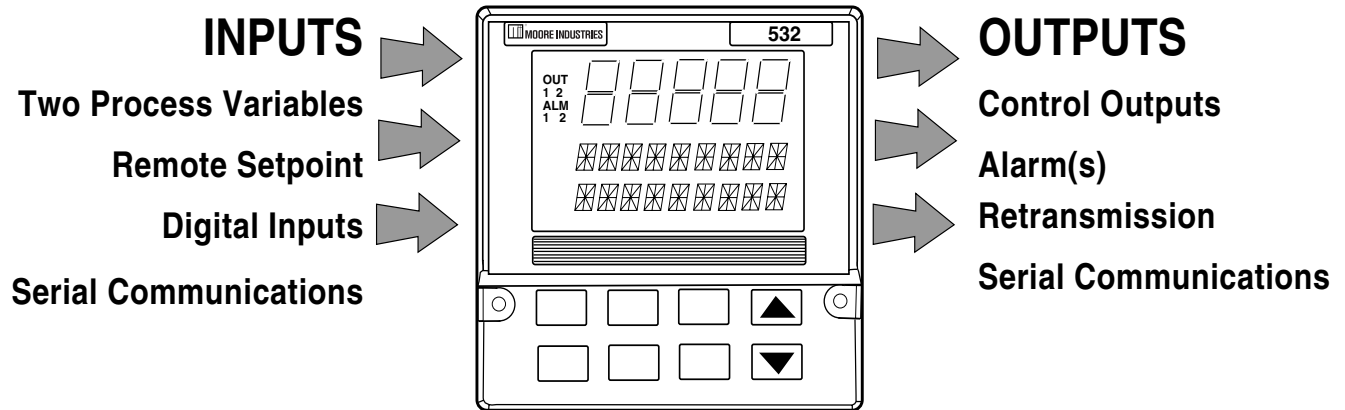

General Description

The **532 Auto/Manual Station** ensures the integrity of your processes with maximum reliability. Isolated inputs and outputs guard against electrical interference, the front faces meet NEMA 4X standards for watertight operation, and solid metal housings and sturdy rubber keys enhance durability.

The station has three digital display areas, two of which offer up to 9 characters of true alphanumeric. The bright, crisp vacuum fluorescent displays offer better readability than any other display technology. Additional operator friendly features include: custom programmable alarm messages, keys that illuminate when in use and an easy-to-use menu system.

Thank you for selecting the 532 Auto/Manual Backup Station. It is the most sophisticated instrument in its class, and will provide you with years of reliable, trouble-free performance.

532 Auto/Manual Backup Station

The 532 has been engineered to be the industry's most user friendly and comprehensive Auto/Manual Backup Station. The 532 provides automatic and manual control backup for critical control loops. In **Auto** or **Remote mode**, the control signal passes from the **Host** device through the 532 without any degradation. A **Host** device may be a PLC, DCS or process controller. The 532 switches to **Local mode** upon keypad selection, digital input or loss of the Host signal. The 532 generates a control signal based on a predetermined control value (CV), or the last known CV from the **Host**. The operator can modify the CV with the ▲ and ▼ keys. The 532 will transfer to **Remote mode** upon keypad selection, opening of the digital input or return of the **Host** signal. Removal of the 532 from its case or powering down while in **Remote mode** will not disturb the **Host** signal; the 532 is not a point of failure!

With your controller, you should have received:

1. 532 User's Manual
2. Mounting hardware
3. Test sheet
4. Engineering unit adhesive labels (1 sheet)
5. Terminal label

NOTE:

This manual may refer to the 532 Auto/Manual Station as the "532" or either simply as "the station."

NOTE:

If you alter the factory configuration of the modules, this product label code will no longer be valid.

Confirming What Is Included

You can determine which outputs have been installed in your station by comparing your product number to the Order Code on the next page. This product number is printed on the label located on the top of the controller case.

Where to Begin

If you are a first time user of a 532 Auto/Manual Station, we recommend that you read through the entire manual. A variety of special functions to enhance your control capability are detailed throughout the manual.

Overview of the 532 Modes

Operating The 532 is in Operating Mode when you turn it on and usually while operating. From this mode, you can initiate the transition between **Remote** and **Local modes**, acknowledge alarms and monitor conditions. You can also access parameters that directly relate to the transfer functions.

Set Up This sometimes referred to as *configuration*. In Set Up you configure the basic function of the station, like input and output assignments, alarm types and special functions.

Where To Go Next

- First time users, continue to Chapter 2 for information on the operator interface and basic controller operation.
- Chapter 3 contains important installation guidelines.
- Chapter 5 details the controller menus and parameters. Use the flowchart in Appendix A as a graphic guideline when you configure your controller.

ORDERING INFORMATION *

Model 532

RoHS - Yes, if specified on order

1/4 DIN Hot PID Backup Station

532 - 2 1 1 B 0 0

Order Code

Output 1: Alarm

None 0
 Mechanical Relay 1
 Solid State Relay (triac) (1 amp) 3
 DC Logic (SSR drive) 4
 Loop Power 5

Options:

None 0
 24 V AC/DC Operation F

None 0
 Set of Three Digital Inputs D
 CE Certification H
 Three Digital Inputs and CE Certification J

Serial Communications:

None 0
 RS-485 Serial Communications S

CHAPTER 2 BASIC OPERATION

The individual software and hardware options of your station determine which information it will display. Compare the product number (on the product label) to the Order Code in Chapter 1.

532 Operator Interface

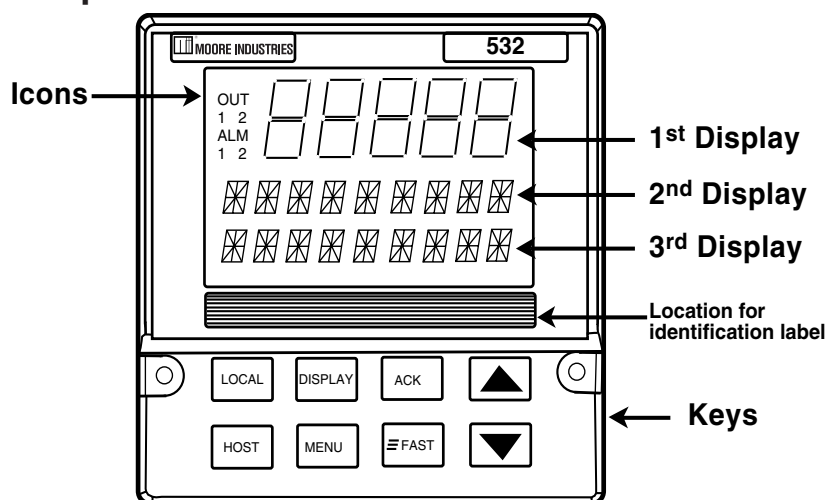

NOTE:

Any modifications to the factory settings of the output modules will render the product label code invalid.

NOTE:

The 532 features **smart menus**; only those messages relevant to your hardware and software configuration will appear. See Chapter 5 for details.

Figure 2.1
532 Operator Interface

Displays:

1st Display

- 5 digits, seven segments. 15mm (0.6in) high.
- Normally displays CV in tenths of a percent.
- If PV option is chosen, will display PV.

2nd Display

- 9 characters, 14 segment alphanumeric. 6mm (0.25 in) high.
- If only PV option is chosen, displays CV.
- If only 2nd input option is chosen, shows SP or VP (valve position).
- If PV and 2nd input options are chosen, automatically alternates between CV and the SP (or VP) at 2 second intervals. Pressing the ▲ or ▼ key to change the output value immediately stops the alternating and displays the CV. Alternating resumes if there is no key activity for 2 seconds.
- During Set Up, displays configuration information.

3rd Display

- 9 characters, 14 segment. 6mm (0.25 in) high.
- If no alarm messages are queued, displays user-selectable station name.
- If errors or alarms are queued, displays messages that alternate every 2 seconds.
- During Set Up, displays configuration information.

NOTE:

If the station loses the PV, SP or VP signal, “-----” will appear in place of the numeric value in the 1st or 2nd display. Refer to Appendix C for more information.



Icons:

ALM1 and ALM2 Icons:

Indicates respective alarm is active.

Keys:



LOCAL

Press key: Transfers station between **Local** and **Remote modes**.

Illuminated: Station is in **Local mode**.



HOST

Press key: Has no effect; used for indication only.

Illuminated: 532 senses CV signal from the Host.



DISPLAY

Press key: Exits the configuration menus and returns station to operation mode.

Key does not light.



MENU

Press key: Accesses the Operation menus.

Illuminated: Station is in Set Up (configuration) mode.



ACK

Press key: Acknowledges alarms.

Illuminated: When an acknowledgeable alarm exists.



FAST

Press key: Functions as a “shift” key; for use with other keys.

Key does not light.



▲ or ▼

Press key: Increases or decreases the value or selection of the current parameter.

Keys do not light.



FAST + ▲ / FAST + ▼

Press keys: Changes parameter value or selection with a larger increment.



FAST + MENU

(Hold down **FAST**, press **MENU**) In **Local** or **Remote mode**, provides entry into the Set Up mode. In Set Up, advances from Menu to Menu .

532 Operating Procedures

This is a quick guide to key operating functions of the 532.

1. To change from REMOTE to LOCAL mode

- a. Press the **LOCAL** key to shift from **Remote** to **Local**. The **LOCAL** key remains lit while in **Local mode**.
- b. The 532 stops passing the **Remote (Host)** signal, and transmits its own signal. This will be either the last known **Host** signal or one of two predetermined outputs.
- c. If you have selected a predetermined CV, you may specify (during Set Up) the rate of change from the remote value to the new value (also known as a RAMP).

2. To change from LOCAL to REMOTE mode

- a. Press the **LOCAL** key to shift from **Local** to **Remote**. The **LOCAL** key will extinguish.
- b. The 532 will stop transmitting its own signal and pass the signal from the **Host** device to the final control element
- c. The transfer will be direct unless a ramp rate was chosen during setup.

3. To change output values in LOCAL mode

- a. Press **LOCAL** key to shift from **Remote** to **Local**.
- b. Press ▲ to increase, or ▼ to decrease the CV value.

4. To override security

- a. If someone attempts a locked operation, the word SECURITY appears in the 2nd display, and the security code starting value (0) appears in the 3rd display.
- b. Select the security code using ▲ and ▼. To “enter” the displayed value as a code, leave the keys inactive for 2 seconds.
- c. If no code was entered (value left at 0), the Security message disappears and the station resumes operation.
- d. If the code is incorrect, INCORRECT appears in the 3rd display. After 2 seconds, the station returns you to step 4b to enter another code.
- e. If the code is correct, CORRECT appears in the 3rd display. After 2 seconds, the displays clear and you have temporary access to all previously locked features. Security will automatically rearm (lock) the station once you leave the keys inactive for 1 minute.
- f. If the **Security Override Code** is entered, RESET appears in the 3rd display. After 2 seconds, the displays clear and the station’s security functions are all reset to their factory defaults (all unlocked).

NOTE:

For more information on Security functions, see Chapter 6.

NOTE:

Powering down the controller acknowledges/clears all latched alarms. When powering up, all alarms will be reset according to their power-up configuration (see Chapter 6).

NOTE:

All alarms are internal alarms unless tied to an output relay in the Set Up mode.

532 Alarm Operation

IMPORTANT NOTICE!

Alarms can be used to provide warnings of unsafe conditions. Therefore, all 532 operators must know how the alarms are configured, how to react to alarm conditions, and the consequences of acknowledging (noting and clearing) an alarm.

Alarm Indication

The 532 indicates alarms by:

- Lighting icons
- Displaying messages; and
- Lighting the **ACK** key, if an alarm is in an acknowledgeable state.

Alarm Acknowledgment

An alarm is acknowledgeable only when the **ACK** key is illuminated. To acknowledge an alarm:

1. Press the **ACK** key to acknowledge Alarm 1. This clears the alarm and releases the relay (if applicable).
2. Both the icon and message indicators disappear, and the relay (if applicable) changes state.
3. If a second alarm is active and acknowledgeable, press the **ACK** key again to acknowledge Alarm 2.

Figure 2.2 shows the controller face during an alarm condition, and then, after the alarm has been acknowledged.

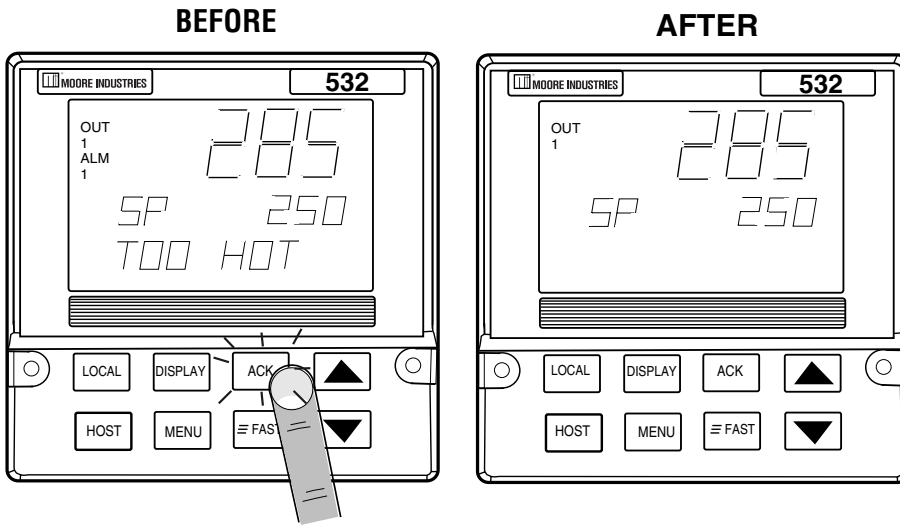

Figure 2.2
Before and After Acknowledging
an Alarm

Latching Alarms

A **latching** alarm will hold its alarm state even after the process leaves the alarm condition. This is useful for stations that will not be continually monitored by an operator. A latching alarm can be configured to be acknowledgeable while in the alarm condition OR only after the process leaves the alarm condition. A **non-latching alarm** will clear itself as soon as the process leaves the alarm condition.

Limit Sequence

An alarm can be configured to be **both** latching and non-acknowledgeable. In this case, the alarm is acknowledgeable only after the process has left the alarm condition. This is often referred to as a **limit sequence** because it behaves like a limit controller.

More on Alarms

For more on alarm types and set ups, see Chapter 6.

CHAPTER 3

HARDWARE SET UP

The configuration of the 532 hardware determines which outputs are available and the types of indicator signals that will be used. **Your station comes factory set with the following:**

- All the specified modules and options installed (see product label and compare to Order Code in Chapter 1);
- Process variable, setpoint and/or valve position inputs set to accept a milliamp input;
- Relay outputs set to normally open.

If you need to change any modules or any other settings, read the rest of this chapter. Otherwise, move on to Chapter 4.

NOTE:

If you would like your controller configured at the factory, please consult an application engineer.

NOTE:

Any changes you make to the output modules will render the code on the product label invalid.

CAUTION!

Static discharge will cause damage to equipment. Always ground yourself with a wrist grounding strap when handling electronics to prevent static discharge.

Hardware Settings

The locations of certain jumpers and module on the printed circuit boards will allow different types of inputs and outputs to be connected to the stations. Figure 3.1 shows the position of these circuit boards inside the station. To access these boards:

1. With power off, loosen the two captive front screws with a Phillips screwdriver.
2. Slide the chassis out of the case by pulling on front face plate assembly at the bezel. Remove the two screws now.

NOTE:

Your hardware configuration will influence the available software options in Chapter 5.

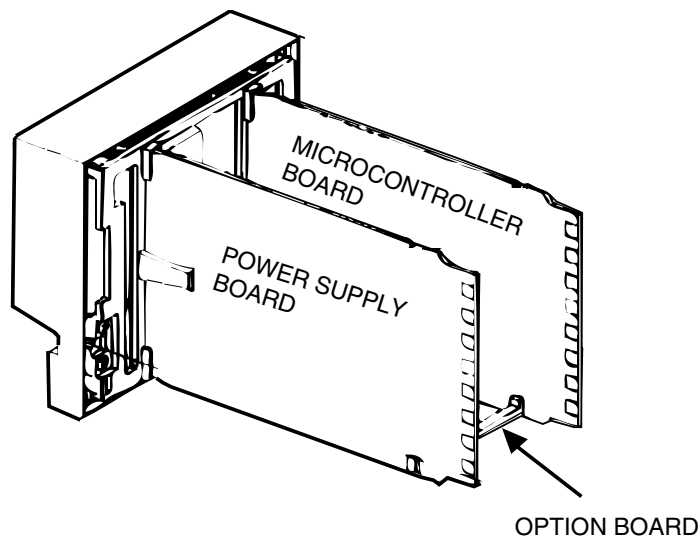

Figure 3.1
Location of Printed Circuit Boards for Hardware Configuration

Figure 3.2
The Microcontroller Circuit Board

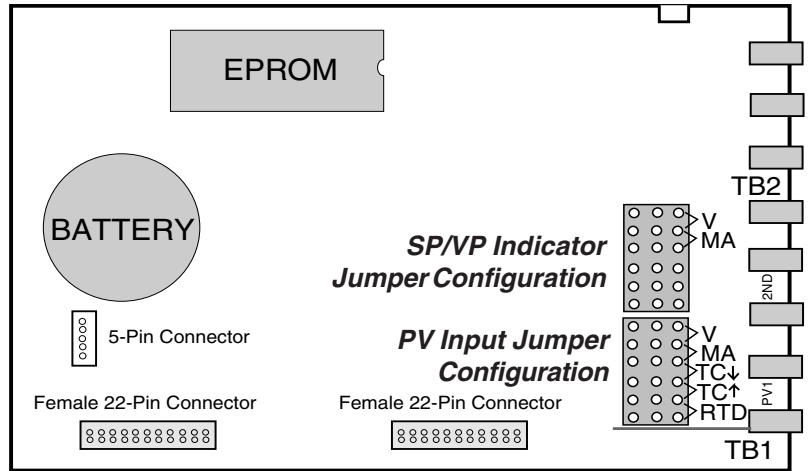

Figure 3.3
The Option Circuit Board

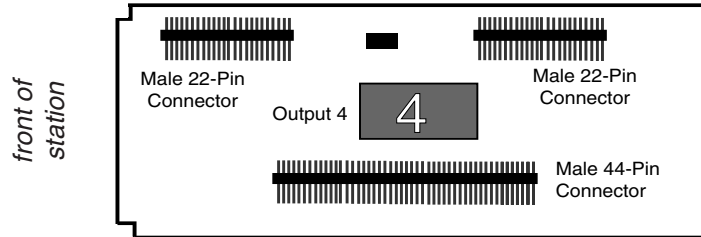
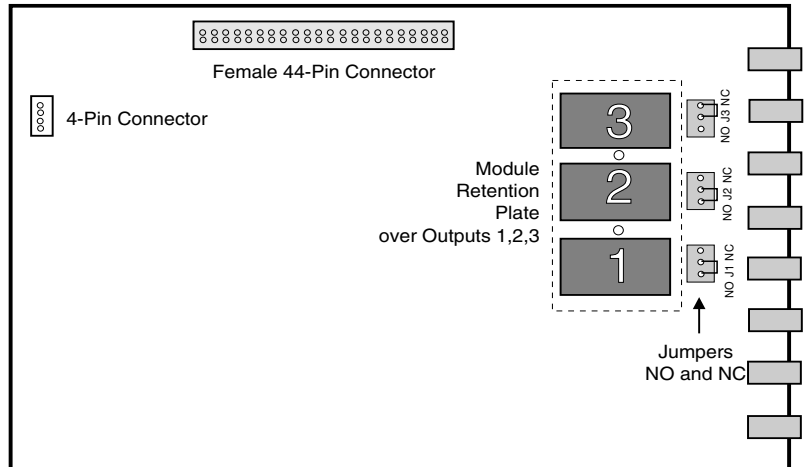

Figure 3.4
The Power Supply Circuit Board



A. Process Variable Indicator Type

The 532 will accept several different types of Process Variable Signals. You specify the type of signal by adjusting the PV jumper location on the Microcontroller Circuit Board, and setting the particular sensor range in the software. The jumper locations for the process variable are marked as follows (see Figure 3.2).

- V Voltage signal
- MA Milliamp
- TC▼ Thermocouple with downscale burnout
- TC▲ Thermocouple with upscale burnout
- RTD RTD

B. Mechanical Relays

There is one output module socket on the Option Board (Figure 3.3), and three on the Power Supply Circuit Board (Figure 3.4). The position of the jumper next to each socket determines whether the relay is configured for Normally Open (NO) or Normally Closed (NC). The output on the options board is always Normally Open (NO).

On the 532, **only the Output 1 relay (if used) may be configured** for normally open or normally closed. **DO NOT make any changes to J2 and J3.**

Hardware Adjustments

A. Accessing and Changing Jumpers

Jumper connectors either slip over adjacent pins, or have pins which insert into adjacent holes. “Changing the jumper” means moving the jumper connectors to alternate pins/holes.

Equipment needed:

- Needle-nose pliers (optional)
 - Phillips screwdriver (#2)
 - Wrist grounding strap
1. With power off, loosen two captive front screws with a Phillips screwdriver.
 2. Slide the chassis out of the case by pulling on front face plate assembly at the bezel. Remove the two screws now.
 3. You will not need to disassemble the chassis to make these adjustments. Refer to Figure 3.3 and Figure 3.4 to locate the jumper connector you want to change.
 4. With either your fingers or the needle nose pliers, pull the jumper connector straight up, as shown in Photo 1. Be careful not to bend the pins.
 5. Move the jumper connector over the desired location and press it straight down, making sure it is seated firmly. Repeat steps 3 and 4 for any others you wish to change.
 6. When you are ready to reassemble the unit, align the boards on the chassis with the cases's top and bottom grooves. Press firmly to slide the chassis into the case. If you have difficulty, check that you have properly oriented the chassis, and there are no screws interfering with the case.
 7. Carefully insert and align screws. Tighten them until the bezel is seated firmly against the gasket.

CAUTION!

Static discharge will cause damage to equipment. Always ground yourself with a wrist grounding strap when handling electronics to prevent static discharge.

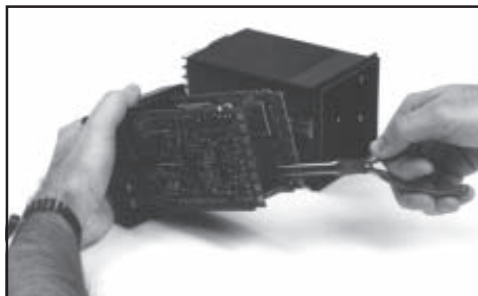

1. Removing jumpers

B. Adding or Changing Output Modules

The 532 has provisions for four output modules. The unit comes factory configured with specified modules installed in appropriate locations. You can make field adjustments by properly removing and/or plugging the modules into the appropriate sockets.

Important Notes:

- Output modules 2, 3 and 4 and Jumpers J2 and J3 **must not be changed** from their factory installation.
- Any output module with a solid state relay or analog module **MUST** have its jumper set at normally open (NO).
- Output 4 is always normally open (NO).

Three of the output sockets are located on the Power Supply Circuit Board. A fourth output socket is located on the Option Board.

Equipment needed:

- Wrist grounding strap
 - Phillips screwdriver (#2)
 - Small flat blade screwdriver
 - Wire cutters
1. With power off, loosen two captive front screws with a Phillips screwdriver.
 2. Slide the chassis out of the case by pulling on front face plate assembly at the bezel. Remove the two screws now.
 3. Locate the retention clips holding the front face assembly to the rest of the chassis. Pry apart these retention clips gently with a screwdriver to separate the printed circuit board group from the front face assembly (Photo 2). Take care not to break the clips or scratch the circuit board.
The Microcontroller Board and Power Supply Board remain attached to the Operator Interface Assembly by wired connectors.
 4. The Microcontroller and Power Supply board are attached to either side of the Option board by male/female pin connectors. Use a gentle rocking motion and carefully apply pressure to separate the larger two boards from the Option Board (Photo 3).

Figures 3.2, 3.3 and 3.4 show the Microcontroller Board, Option Board and Power Supply Board.

5. A retention plate and tie wrap hold Output modules 1, 2, and 3 (on the Power Supply board) firmly in place. To remove the retention plate, snip the tie wrap with wire cutter (Photo 4).

CAUTION! Always snip the tie wrap on top of the Retention Plate to prevent damage to the surface mount components.

6. A disposable tie wrap holds Output

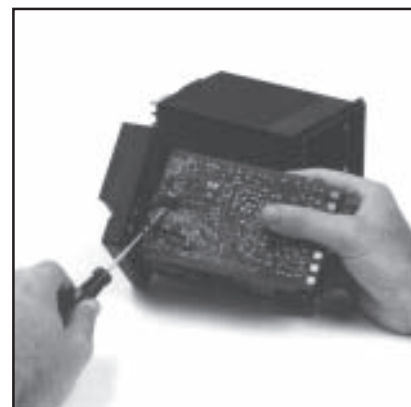

2. Pry Clips

module 4 (on the Option board) in place. To remove the module, snip tie wrap (Photo 5).

7. Inspect each module before installation to make sure the pins are straight (see Figure 3.5). Align the pins with the socket holes and carefully insert the module. Press down on the module to seat it firmly on the board (Photo 6).
8. Replace tie wraps for the Retention Plate and for Output Module 4 with new ones.

Failure to use these devices may result in a loosening of the module and eventual failure. If you ordered a module separately, it should have come with a tie wrap. An extra set of tie wraps is available by ordering Part #535-665.

9. To reassemble the unit: Align the connector pins on the Option Board with the

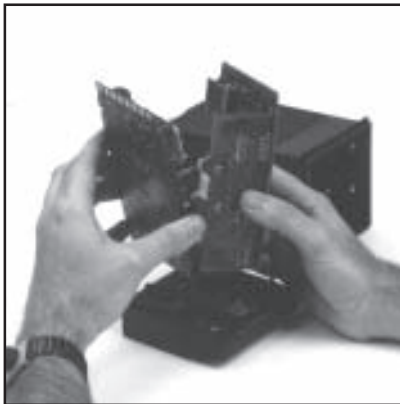

3. Separate Boards

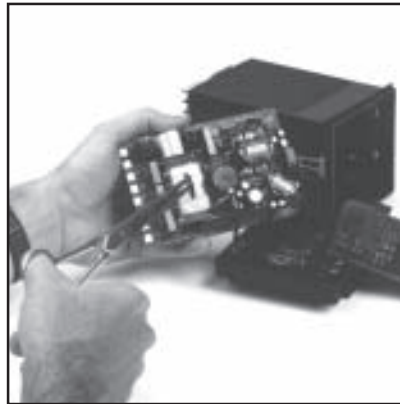

4. Remove Retention Plate

connector sockets on the Microcontroller and Power Supply boards. Squeeze them together, making certain all three are properly seated against one another. Check along the side edges for gaps. Also, check that the cable assemblies are not pinched.

10. Align the board assembly with the front face assembly, with the Option board at the bottom (see Figure 3.1). Reinstall the retention clips. Align the boards



5. Snip Tie Wrap

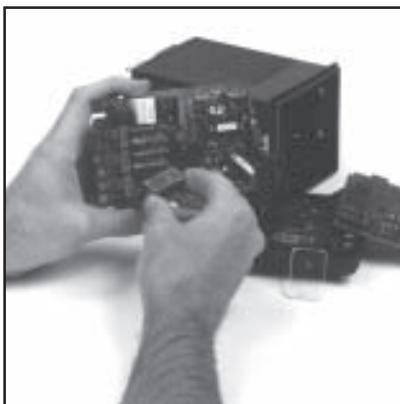

6. Add/Change Module

CAUTION!
Do not scratch the boards or bend the pins of the connectors.

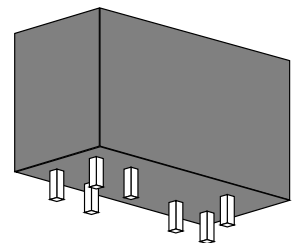

Figure 3.5
Representation of Module (view of bottom)

into the slots of the front face assembly and the clips will snap into place.

- 11.** When you are ready to reassemble the unit, align the boards on the chassis with the top and bottom grooves on the case. Press firmly to slide the chassis into the case. If you have difficulty, check that you have properly oriented the chassis, and there are no screws interfering with the case.
- 12.** Carefully insert and align screws. Tighten them until the bezel is seated firmly against the gasket.

After you have configured the hardware, you may go on to Chapter 4 for installing and wiring the controller.

CHAPTER 4 INSTALLATION & WIRING

The 532 Auto/Manual Station is thoroughly tested, calibrated and “burned in” at the factory, so your station is ready to install. But before you begin, read this chapter thoroughly and take great care in planning your system. A properly designed system can help prevent problems such as electrical noise disturbances and dangerous conditions.

System Planning

A. Consider the Noise Factor

- For improved electrical noise immunity, install the station as far away as possible from motors, relays and other similar noise generators.
- Do not run low power (sensor input) lines in the same bundle as AC power lines. Grouping these lines in the same bundle can create electrical noise interference.

CAUTION!

For safety consideration, **DO NOT** run low power (sensor input) lines in the same bundle as AC power lines.

B. Wiring Practice Resources

An excellent resource about good wiring practices is the IEEE Standard No. 518-1982 and is available from IEEE, Inc., 345 East 47th Street, New York, NY 10017, (212) 705-7900.

Installation

A. Make the panel cutout

The station fits in a standard 1/4 DIN cutout. You may mount your station in any panel with a thickness from .06 to .275 inches (1.5mm to 7.0mm). See Figure 4.1 for dimensions.

If you make a mistake in the panel cutout, you can use a “Goof Plate” (Repair Part #512-014).

Figure 4.1
532 instrument panel and cutout dimensions

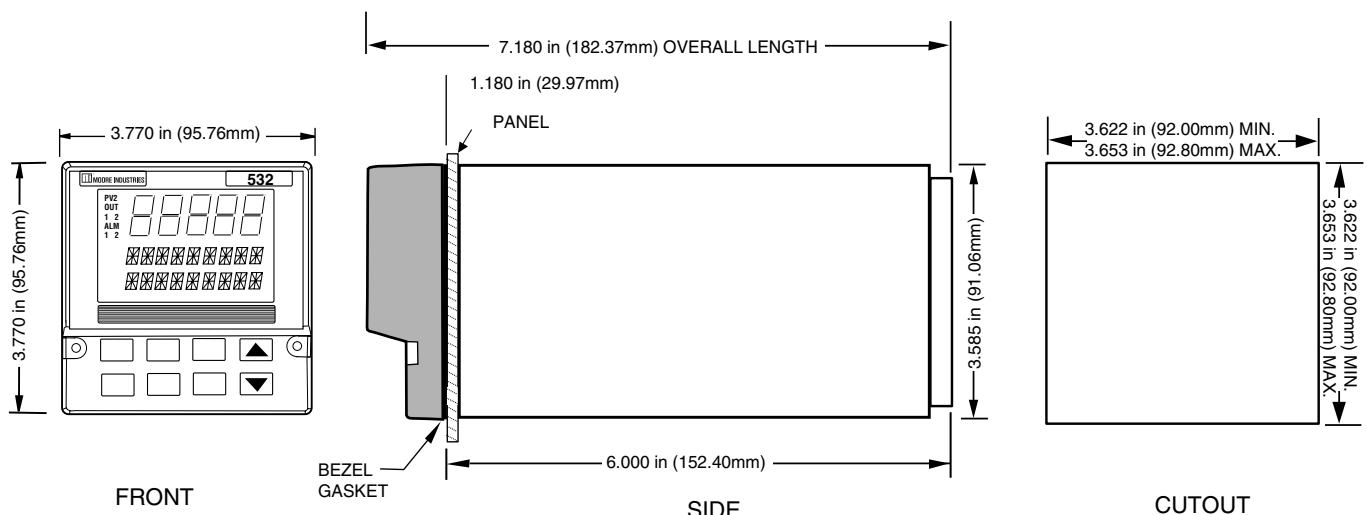

B. Establish a waterproof seal.

The station front face (keys, display, and bezel) are NEMA 4X rated (waterproof). To obtain a waterproof seal between the station and the panel, make sure:

1. The panel cutout is precise;
2. You use a fresh gasket;
3. The edge of the cutout is free from burrs and “waves;”
4. The case of the station are centered in the cutout.

If you require a waterproof seal but have difficulty with these requirements, apply a bead of caulk or silicone sealant behind the panel around the perimeter of the case.

C. Mount station into panel:

The instrument enclosure mounting MUST BE GROUNDED.

You will need a long Phillips screw driver (#2).

1. Turn the instrument with the back towards you. Now slide the gasket around the back of the case, all the way up to the bezel.
2. With the bezel gasket in place, insert the station into the panel cutout from the front of the panel.
3. From behind the panel, insert the mounting clips (one on each side), as shown in Figure 4.2.
4. Gradually tighten the mounting bracket screws.
5. Tighten the screws securely and check bezel gasket to ensure a tight, even seal.

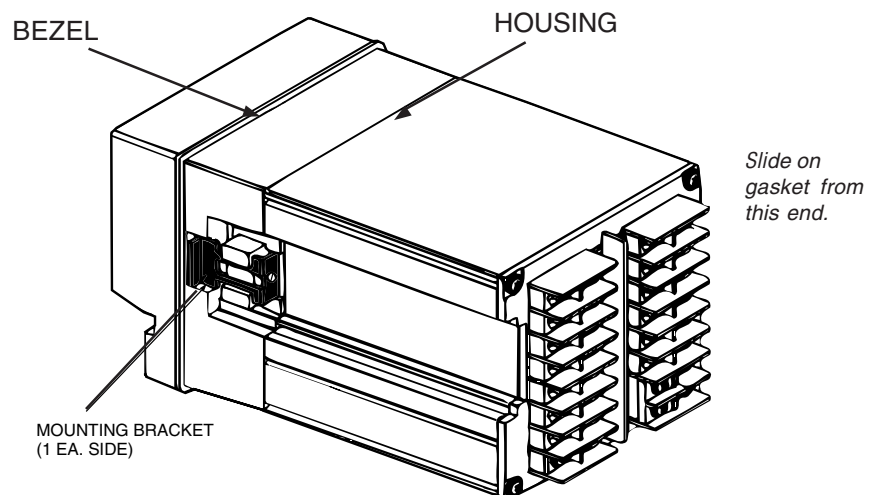

Figure 4.2
Mounting Brackets

Input Wiring for the 532

Figure 4.3 shows the rear terminal configuration for the 532. The actual instrument has only the top and bottom numbers of each column marked. Refer to this diagram when using the following input and output wiring instructions.

NOTE:

All wiring and fusing should conform to the National Electric Code and to any locally applicable codes.

WARNING!

To avoid electric shock, DO NOT connect AC power wiring at the source distribution panel until all wiring connections are complete.

To avoid shock hazard and reduced noise immunity for your system, TERMINAL 9 MUST BE GROUNDED.

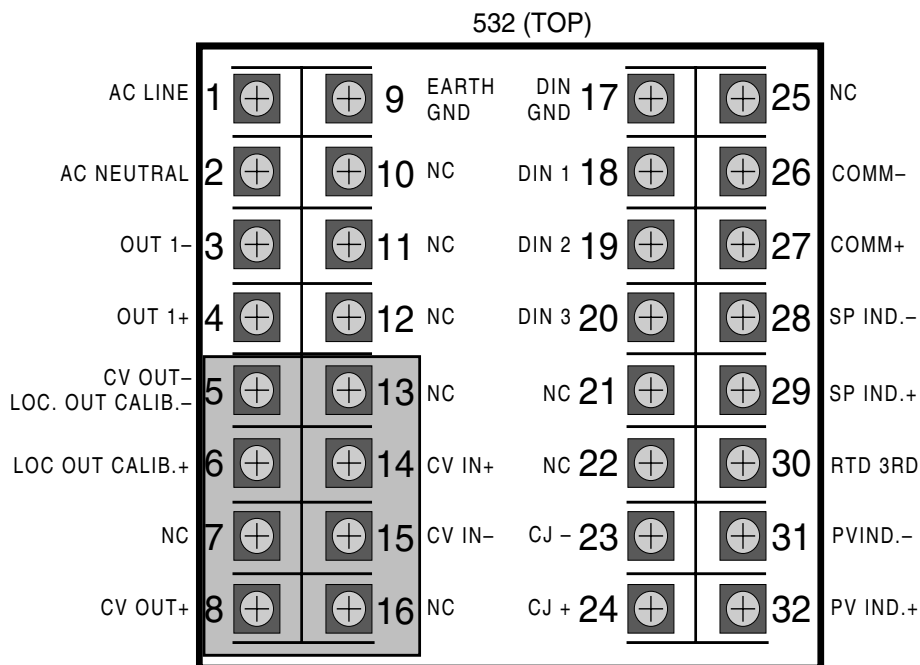

Figure 4.3
532 Rear Terminals

A special PC Board covers terminals 5, 6, 7, 8, 13, 14, 15, and 16.

A. AC Power

Terminals 1 and 2 are the power terminals.

Terminal 9 is the earth ground terminal.

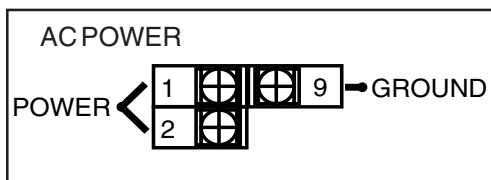

B. Process Variable Indicator

The station accommodates the following types of process variable inputs: Thermocouple, RTD, Voltage, Milliamp (external power supply) and Milliamp (internal power supply).

NOTE:

Use a 0.5 Amp, 250 V, fast-acting fuse in line with your AC power connection (terminal 1).

The following wiring diagrams show how to wire the stations for these different types of process variable.

1. Thermocouple Input

Use terminals 30, 31 and 32 as shown.

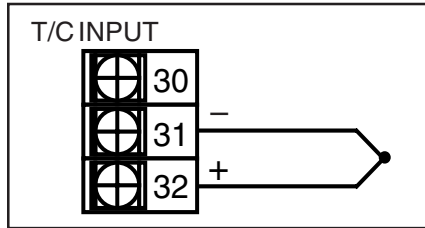

2. RTD Input

For 2, 3 or 4 wire RTD, use terminals 30, 31 and 32 as shown.

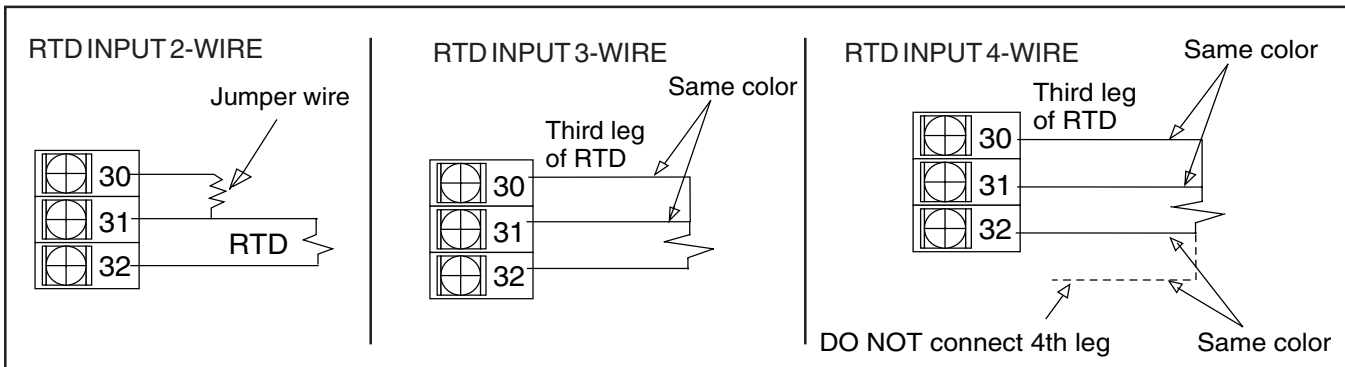

3. Voltage Input

Use terminals 31 and 32 as shown.

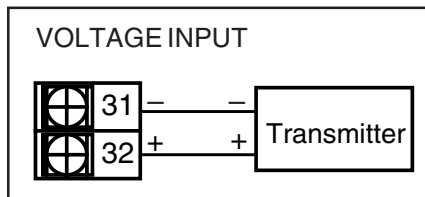

4. Milliamp Input -External Power Supply

Use terminals 31 and 32 as shown.

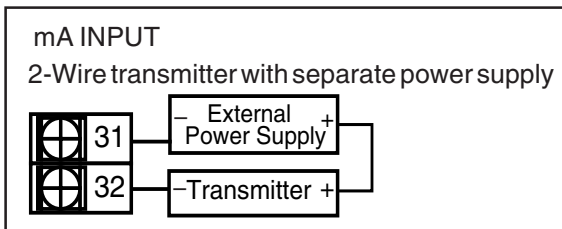

C. Digital Inputs

Digital input(s) can be activated by closure of a relay, a switch, or an open collector transistor. Signal-type relay is recommended.

1. Digital Inputs with a switch

For 1 to 3 digital inputs use terminals 17 to 20 as shown.

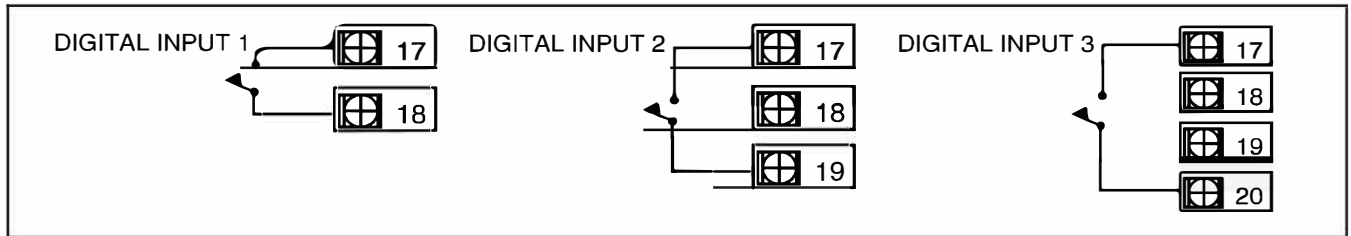

2. Digital Inputs with Open Collector (resistor)/Relay (dry contact)

DIN X represents DIN 1 to DIN 3 (use corresponding terminals).

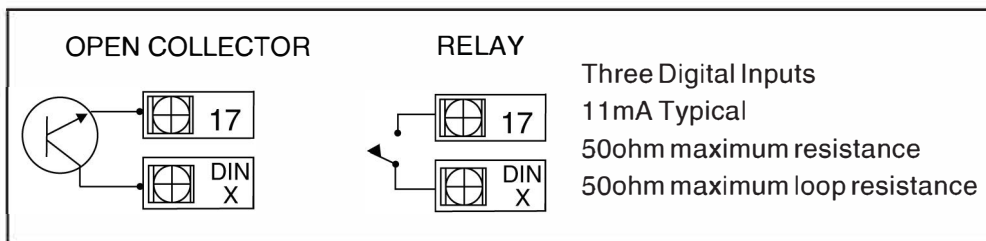

D. Setpoint or Valve Position Indicator

Use terminals 28 and 29 as shown.

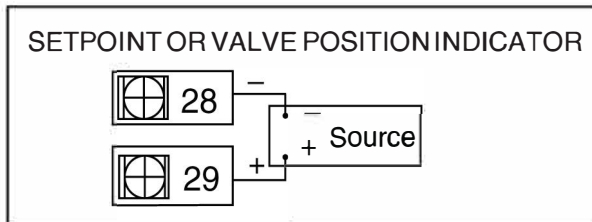

Output Wiring for the 532

- Output 1 is available for use as an alarm with installation of a Mechanical relay or Solid State Relay (Triac) module.
- The 532 is factory configured with an Analog module in Output 2.
- The 532 is factory configured with Mechanical relays in Outputs 3 and 4.
- The 532 cannot be wired for retransmission.
- A small PC board fits over rear terminals 5, 6, 7, 8, 13, 14, 15 & 16.

The following instructions explain how to properly wire the 532 for any particular output module. If you do not know which module(s) have been installed in your station, compare the product number on the product label with the Order Code in Chapter 1.

To add or change position of jumpers or output modules, refer to Chapter 3.

NOTE:

Any modifications to the factory settings of the output modules will render the product label code invalid.

A. CV Output

- Use terminals 5 and 8 for CV Output as shown in Figure 4.4.
- Use terminals 14 and 15 for CV Input

B Mechanical Relay Output

- Use terminals 3 and 4 as shown in Figure 4.4.
- Jumper J1 can be set to normally open (NO) or normally closed (NC) as desired.

C Solid State Relay (Triac) Output

- Use terminals 3 and 4 as shown in Figure 4.4.
- Jumper J1 must be set to normally open (NO).

D. DC Logic (SSR Drive) Output

- Use terminals 3 and 4 as shown in Figure 4.4.
- Jumper J1 must be set to normally open (NO).

Figure 4.4
Output Wiring for the 532

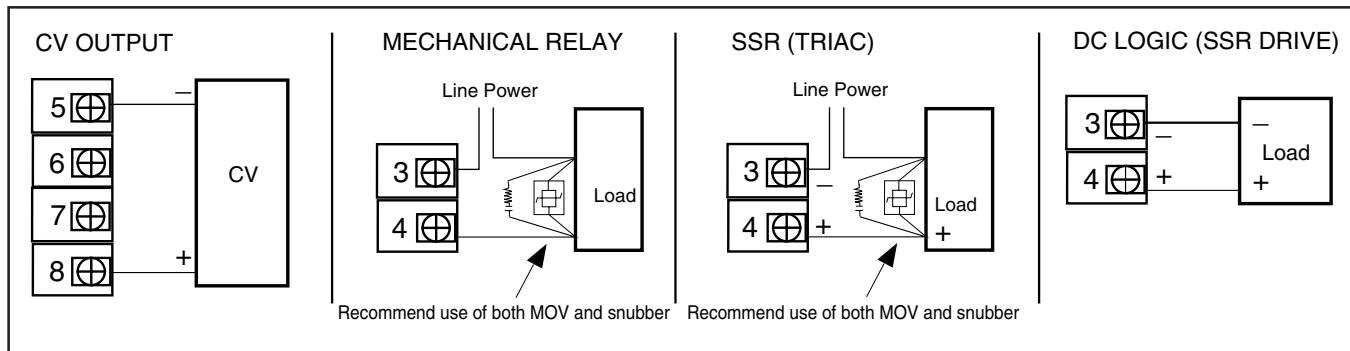

Wiring the Serial Communications Option

Refer to Figure 4.5 for Wiring Diagram.

- Use a twisted shielded pair of wires to connect the host and field units. Belden #9414 foil shield has superior noise rejection characteristics. #8441 braid shield 22-gauge wire has more flexibility.
- The maximum recommended length of the RS-485 line is 4000 ft.
- Termination resistors are required at the host and the last device on the line. Some RS-485 cards/converters already have a terminating resistor. We recommend using RS-232/RS-485 converter (prod. no. 500-485).

Figure 4.5
Serial Communications Terminals

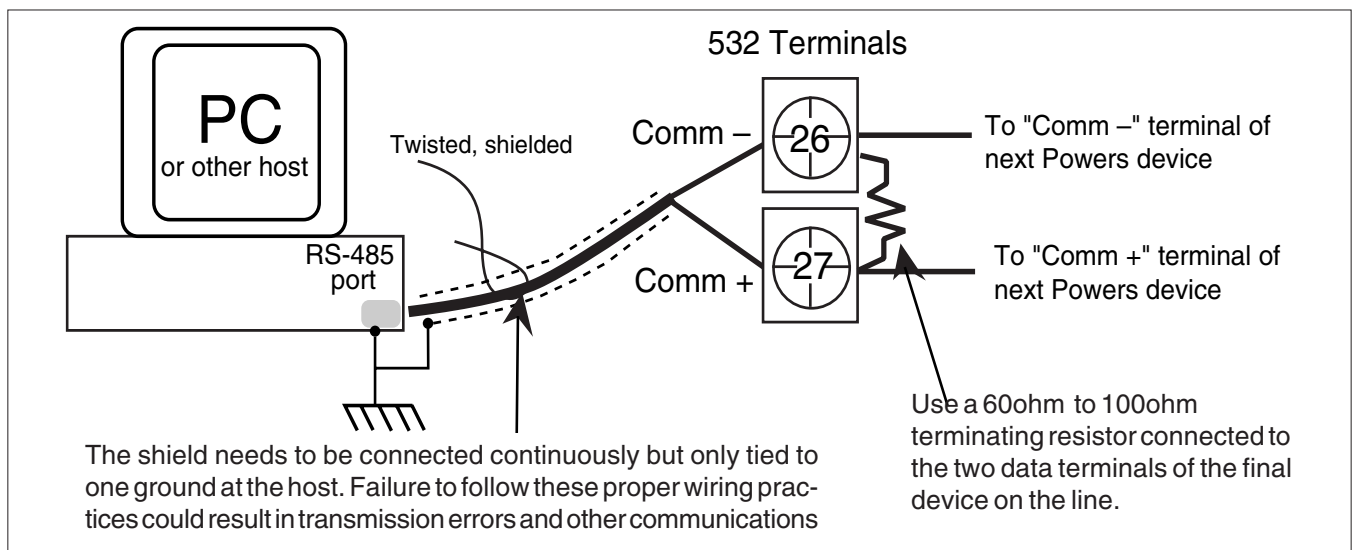

Where to Go Next

For a step-by-step guide on setting up the software features for your controller, see Chapter 5.

CHAPTER 5 SOFTWARE SET UP

Mode Overview

The 532 will be in **Operating Mode** upon power up, and will remain in Operating Mode most of the time it is performing its functions. This is not the same as the **OPERATIONS** menu.

In **Set Up Mode**, you can access menus of operation parameters that affect the display and adjustment of the stations.

Figure 5.1 illustrates the relationships between the different modes of the 532 station, and the different Set Up menus.

Menus

A **menu** is a group of Set Up **parameters**. The name of a menu appears in the 2nd display of the 532 station during your set up. Once inside a menu, the different parameters will appear in the 2nd display. The **values/options** for each parameters will appear in the 3rd display. On the station, the menu name appears in the display at the beginning of the cycle of the menu.

These are the possible menu for your station, and their applications.

- CONFIG.:** To configure the input and output hardware assignments.
- LOCAL OUT.:** To configure the local output control.
- PV INPUT:** To configure the process variable (PV) indicator.
- CUST. LINR:** To configure the custom linearization curve for the PV indicator.
- SP INPUT:** To configure the set point indicator.
- VP INPUT:** To configure the valve position indicator.
- ALARMS:** To configure alarms.
- SECURITY:** To configure the security function.
- SER. COMM.:** To configure serial communications.
- OPERATIONS:** To make adjustments to the transition [between **Remote** (Host) and **Local** control] functions of the station.

Smart Menu

This chapter outlines, in sequence, **all** menu, parameters, and selections available for the 532 station. However, the “**smart menu**” feature of the stations allows only those menu and Parameters to appear that are relevant to your hardware and software configuration, i.e., **parameters which do not apply to your application will not appear on your station’s display.**

NOTE TO ALL USERS:

Be sure to read and understand the next two pages, which contain important information on how to use this guide to help you to set up the instrument. The *Parts of the Menu* section explains the graphic used in the Set Up and Tuning configuration sections.

Figure 5.1
Menu Flowchart for Set Up

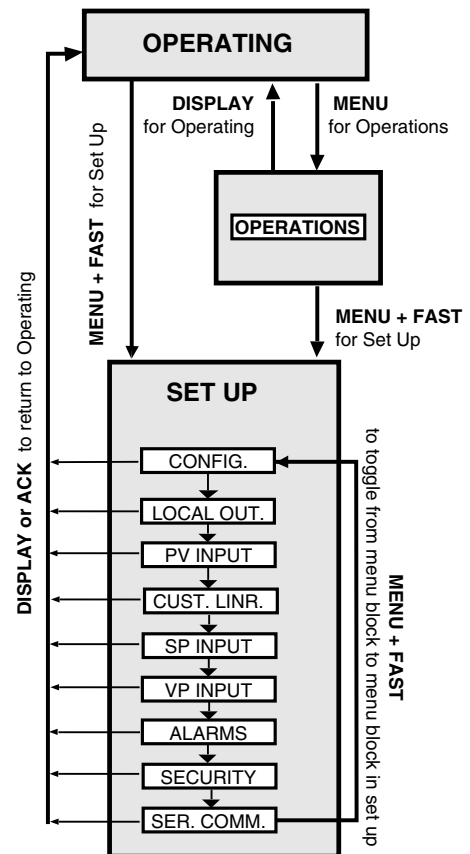

PV TYPE	INDICATOR
(D)	NONE

Figure 5.2
Independent Parameters versus
Dependent Parameters

- Parameters that apply to all configurations of the 532 appear in this manual as a white on white box (Figure 5.2, *left portion*). These parameters are **independent** of your configuration.
- Parameters that **depend** on the configuration of the individual station appear as a black on white box (Figure 5.2, *right portion*).

Be aware that changing one parameter's selection (or value) may affect another parameter. See the **PV INPUT** menu section for an example on how this can affect your low and high range values.

Set Up Procedures

On the bottom of each page is a guide to the keypad, to use during the Set Up procedure.

To Enter the Set Up Mode

- Hold down the **FAST** and press **MENU**. (see Figure 5.3). The **MENU** key will illuminate. The first menu, **CONFIG.**, appears alone in the 2nd display.

To Advance through Menus

- Press **FAST + MENU** to advance to the next menu. The name will appear in the 2nd display.

To Enter a Menu and Advance through Parameters

- When you reach your chosen menu, press **MENU**. The first parameter of this menu appears in the 2nd display, replacing the menu name. The first values/selection for the particular parameter appears in the 3rd display.
- Press **MENU** to advance to next parameter.

To Advance through Values/Selections for a Parameter

- Press **▲** or **▼**.

To Return to Operating Mode

- If you are in Set Up Mode, press the **DISPLAY** key. The 532 will return to Operation Mode.

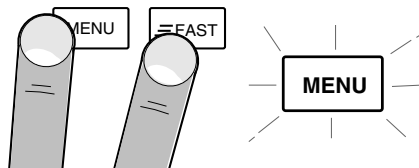

Figure 5.3
Keys to Enter and Move through
Set Up Mode

WARNING!!

Scrolling through the choices to make selections will affect the operation of the instrument since changes to parameter selections occur in "real time" or immediately.

DO NOT MAKE ANY CHANGES WHILE ON LINE (DURING OPERATION).

Escape to Operation Mode	DISPLAY	Next Parameter	MENU	Next Block	≡FAST +	MENU	Next value	▲ OR ▼
--------------------------	----------------	----------------	-------------	------------	----------------	-------------	------------	----------------------

Step-by-Step Guide to Software Set Up

REMEMBER: Only parameters and selections relevant to your hardware and other software selections will appear on your station.

(D) Indicates Default Setting

(R) Indicates a range of values

CONFIG.

CONFIG

For configuring the input and output hardware assignments.

1. INDICATOR

Enables indicator for PV and/or a 2nd input.

- (D) NONE No display
- PV Display Process Variable
 - 2ND Enable 2ND INPUT parameter
 - PV/2ND Display PV and enable 2ND INPUT

INDICATOR

NONE

2. 2ND INPUT

Chooses indicator for 2nd input, a retransmitted VP or SP (provided 2ND or PV/2ND selection is made in INDICATOR parameter).

- (D) VP Display Valve Position
- SP Display Setpoint

2ND INPUT

VP

3. LINE FREQ

Specifies the power source frequency

- (D) 60 Hz
- 50 Hz

LINE FREQ

60

4. OUTPUT 1

Defines the function of the first output.

- (D) OFF Completely deactivates output
- ALARM Digital only
 - COMM. ONLY Output addressable only through communications

OUTPUT 1

OFF

5. CONTACT 1

Defines the operation of the 1st digital input.

- (D) LOCAL.LAST Switch to **Local**, hold last out value seen from host
- LOCAL.PRE1 Switch to **Local**, set LOCAL OUT to Preset 1 value
 - LOCAL.PRE2 Switch to **Local**, set LOCAL OUT to Preset 2 value
 - ALARM ACK. Acknowledges alarms
 - UP KEY Remote ▲ function
 - DOWN KEY Remote ▼ function
 - COMM.ONLY Makes status readable through communicatoins.

CONTACT 1

LOCAL.LAST

Escape to Operation Mode

DISPLAY

Next Parameter

MENU

Next Block

≡FAST

+

MENU

Next value

▲

OR

▼

CONFIG

CONTACT 2

LOCAL.PRE1

CONTACT 3

LOCAL.PRE2

STN.NAME

BYPASSER

LOCAL OUT.

LOW LIMIT

0.0

HIGH.LIMIT

100.0

PWR.UP:MODE

LAST

6. CONTACT 2

Defines the operation of the 2nd digital input.

- LOCAL.LAST Switch to **Local**, hold last out value seen from host
- (D) LOCAL.PRE1 Switch to **Local**, set LOCAL OUT to Preset 1 value
- LOCAL.PRE2 Switch to **Local**, set LOCAL OUT to Preset 2 value
- ALARM ACK. Acknowledges alarms
- UP KEY Remote▲ function
- DOWN KEY Remote▼ function
- COMM.ONLY Makes status readable through communications.

7. CONTACT 3

Defines the operation of the 3rd digital input.

- LOCAL.LAST Switch to **Local**, hold last out value seen from host
- LOCAL.PRE1 Switch to **Local**, set LOCAL OUT to Preset 1 value
- (D) LOCAL.PRE2 Switch to **Local**, set LOCAL OUT to Preset 2 value
- ALARM ACK. Acknowledges alarms
- UP KEY Remote▲ function
- DOWN KEY Remote▼ function
- COMM.ONLY Makes status readable through communications.

8. STN.NAME

Allows you to enter a nine character message to name the station. The first character of the 3rd display will be flashing. Press arrow keys to scroll through character set. Press **FAST** to enter the selection and move to next digit. Press **MENU** to advance to next parameter.

(D) BYPASSER

LOCAL OUT.

To configure the local output control.

1. LOW LIMIT

Selects how low the output can be manually adjusted.

(R) -5.0% to 105%

(D) 0.0%

2. HIGH.LIMIT

Selects how high the output can be manually adjusted.

(R) -5.0% to 105%

(D) 100.0%

3. PWR.UP:MODE

Selects the power-up mode.

(D) LAST

Escape to Operation Mode

DISPLAY

Next Parameter

MENU

Next Block

≡FAST

+

MENU

Next value

▲

OR

▼

Software Set Up

CONFIG

- LOCAL
- REMOTE

4. PWR. UP:OUT.

Selects the power-up output for the 532 in local mode.

- (R) -5.0% to 105.0%
- (D) LAST OUT

PWR.UP:OUT

LAST OUT

PV INPUT

For configuring the process variable (PV) input. The whole menu appears only if PV indicator is enabled.

1. PV TYPE

Selects the particular sensor or input range.

PV INPUT

PVTYPE

(D)

USE THE ARROW KEYS TO MAKE APPROPRIATE SELECTION BASED ON YOUR PROCESS VARIABLE TYPE

T/C Input:	RTD Input:	Voltage Input:	Current Input:
<ul style="list-style-type: none"> • J T/C • E T/C • K T/C • B T/C • N T/C • R T/C • S T/C (D) T T/C • W T/C • W5 T/C • PLAT.II T/C 	<ul style="list-style-type: none"> (D) DIN RTD • JIS RTD • SAMARTD 	<ul style="list-style-type: none"> (D) 1-5V • 0-5V • 0-10mV • 0-30mV • 0-60mV • 0-100mV • +/-25mV 	<ul style="list-style-type: none"> (D) 4-20mA • 0-20mA

CAUTION!
Changing certain parameter selections may affect other parameter values. Be careful when changing parameters out of presented order.

2. DEG. F/C/K

Selects the temperature unit if using a thermocouple or RTD.

- (D) FAHR.
- CELSIUS
- KELVIN

DEG. F/C/K

FAHR.

3. DECIMAL

Specifies the decimal point position.

For V/mA Input:	For RTD Input:
(D) XXXXX	(D) XXXXX
• XXXX.X	• XXXX.X
• XXX.XX	
• XX.XXX	
• X.XXXX	

DECIMAL

XXXXX

Escape to Operation Mode

DISPLAY

Next Parameter

MENU

Next Block

≡FAST

+

MENU

Next value

▲

OR

▼

PV INPUT

LINEARIZE

NONE

LOW RANGE

(D)

HI RANGE

(D)

FILTER

0

PV OFFSET

0

PV GAIN

1.000

CUST.LINR.

NOTE:

If you make any modifications to a set curve, you must re-enter all points in order, from 1 to X. Use the Set Up Charts on page 36 to record your data.

1ST. INPUT

(D)

4. LINEARIZE

Specifies how to linearize the input. For V/mA Input only (Thermocouple and RTD inputs are automatically linearized).

- (D)** NONE Normal linearization (2 point)
- SQR. ROOT Square root linearization
- CUSTOM 15-point custom linearization curve

5. LOW RANGE

Specifies the engineering unit value corresponding to the lowest input value, e.g. 4mA. For V/mA input only.

- (R)** -9999 to 99999, Maximum value is HI RANGE
- (D)** Dependent on the input selection.

6. HI RANGE

Specifies the engineering unit value corresponding to the highest input value, e.g. 20mA. For V/mA input only.

- (R)** -9999 to 99999, minimum value is LOW RANGE
- (D)** Dependent on the input selection

7. FILTER

Defines the setting for the low pass input filter.

- (R)** 0 to 120 seconds
- (D)** 0

8. PV OFFSET

Defines the offset to the process variable in engineering units.

- (R)** -9999 to 99999
- (D)** 0

9. PV GAIN

Defines the gain to the process variable. For V/mA input only.

- (R)** 0.100 to 10.000
- (D)** 1.000

CUST. LINR.

Defines a custom linearization curve for the process variable input. You need to specify each of the curve's 15 points. The first two points define the slope of the curve (positive or negative). All subsequent points must support this slope, i.e., the curve must be ever-increasing or ever-decreasing.

1. 1ST. INPUT

Specifies the input signal corresponding to the first point.

- (D)** The low end of the appropriate input range (e.g., 4.00mA)

Escape to Operation Mode

DISPLAY

Next Parameter

MENU

Next Block

≡FAST

+

MENU

Next value

▲

OR

▼

Software Set Up

2. 1ST. PV
Specifies engineering unit value corresponding to the first point.
(R) -9999 to 99999
(D) Dependent on the LOW RANGE value
3. 2ND. INPUT
Specifies the input signal corresponding to the second point.
(R) Any value greater than the 1ST. INPUT
(D) The low end of the appropriate input range (e.g., 4.00mA)
4. 2ND. PV
Specifies engineering unit value corresponding to the second point.
(R) -9999 to 99999
(D) Dependent on the LOW RANGE value
5. XTH. INPUT
Specifies the input signal corresponding to the Xth point (up to 15).
(R) Any value greater than the previous (XTH-1) input.
(D) The high end of the appropriate input range (e.g. 4.00mA)
6. XTH. PV
Specifies engineering unit value corresponding to Xth point (up to 15).
(R) -9999 to 99999
(D) Dependent upon the LOW RANGE value

CUST.LINR.

1ST. PV

(D)

2ND. INPUT

(D)

2ND. PV

(D)

XTH. INPUT

(D)

XTH. PV

(D)

SP INPUT

SP INPUT

For configuring the setpoint indicator.

1. SP TYPE
Specifies type of input signal that will be used for the setpoint indicator.
If the jumper is in the mA position:
(D) 4-20mA
 - 0-20mA**If the jumper is in the V position:**
(D) 1-5V
 - 0-5V
2. SP LOW
Specifies the engineering unit value corresponding to the lowest setpoint indicator input value, e.g. 4mA.
(R) -9999 to 99999
(D) 0

SP TYPE

(D)

SP LOW

0

Escape to Operation Mode

DISPLAY

Next Parameter

MENU

Next Block

≡FAST

+

MENU

Next value



OR



SP INPUT

SP HIGH

1000

SP DISPLAY

SETPOINT

3. SP HIGH

Specifies the engineering unit value corresponding to the highest setpoint indicator input value, e.g. 20mA.

(R) -9999 to 99999

(D) 1000.

4. SP DISPLAY

Selects whether to display SP as an actual setpoint (SP) or as a deviation from the current PV indicator value (PV-SP).

(D) SETPOINT

- DEVIATION

VP INPUT

VP TYPE

(D)

VP INPUT

For configuring the valve position indicator.

1. VP TYPE

Specifies type of input signal that will be used for the valve position indicator.

If the jumper is in the mA position:

(D) 4-20mA

- 0-20mA

If the jumper is in the V position:

(D) 1-5V

- 0-5V

2. VP LOW

Specifies the engineering unit value corresponding to the lowest valve position indicator input value, e.g. 4mA.

(R) -9999 to 99999.

(D) 0

3. VP HIGH

Specifies the engineering unit value corresponding to the highest valve position indicator input value, e.g. 20mA.

(R) -9999 to 99999.

(D) 1000

NOTE:

You may configure you station for SP Input or VP Input, but not both.

VP LOW

0

VP HIGH

1000

ALARMS

ALARMS

For configuring alarms.

1. ALM. TYPE:1

Defines the type of alarm for alarm 1.

(D) OFF

Deactivates the first alarm

ALM.TYPE:1

OFF

Escape to Operation Mode

DISPLAY

Next Parameter

MENU

Next Block

≡FAST

+

MENU

Next value



OR



ALARMS

- LOCAL Causes an alarm when in local control
- HIGH ALARM.
- LOW ALARM
- RATE Selects a rate-of-change alarm
- BAND
- DEVIATION

NOTE:

Band and Deviation Alarm choices appear only if you use SP Indication.

2. ALARM SP:1

Specifies the alarm set point for alarm 1.

If ALM. TYPE:1 = RATE

(R) -9999 to 99999

(D) Dependent on the LOW RANGE value.

IF ALM. TYPE:1 is any other type

(R) process variable range

(D) Dependent on the LOW RANGE value

ALARM SP:1

(D)

3. DEADBAND:1

Defines the deadband for alarm 1.

(R) 1 to 9999

(D) 2.

DEADBAND:1

2

4. RELAY:1

Defines the state of the relay in the alarm condition for alarm 1.

(D) RELAY ON

- RELAY OFF

RELAY:1

RELAY ON

5. LATCHING:1

Defines the latching sequence of alarm 1.

(D) LATCH

- NO LATCH

LATCHING:1

LATCH

6. ACK.:1

Defines whether alarm 1 may be acknowledged.

(D) ENABLED Allows the alarm to be acknowledged

- DISABLED Prevents existing alarm from being acknowledged

ACK.:1

ENABLED

7. POWER UP:1

Defines how alarm 1 will be treated on power up.

(D) NORMAL Alarm depends on process variable

- ALARM Power up in alarm regardless of PV
- DELAYED Must leave alarm condition and reenter before activating the alarm

POWER UP:1

NORMAL

ALARMS

MESSAGE:1

ALARM 1

ALM. TYPE:2

OFF

ALARM SP:2

(D)

DEADBAND:2

2

RELAY:2

RELAY ON

LATCHING:2

LATCH

8. MESSAGE:1

Allows you to enter a nine character message associated with alarm 1. The first character of the 3rd display will be flashing. To enter message, press arrow keys to scroll through character set. Press **FAST** to enter the selection and move to next digit. Press **MENU** to advance to next parameter.

(D) ALARM 1

9. ALM. TYPE:2

Defines the type of alarm for alarm 2.

- (D) OFF Deactivates the second alarm
- LOCAL Causes an alarm when in local control
 - HIGH ALRM.
 - LOW ALARM
 - RATE Selects a rate-of-change alarm
 - BAND
 - DEVIATION

10. ALARM SP:2

Specifies the alarm set point for alarm 2.

If ALM. TYPE:2 = RATE

(R) -9999 to 99999

(D) Dependent on the LOW RANGE value.

If ALM. TYPE:2 is any other type

(R) process variable range

(D) Dependent on the HIGH RANGE value

11. DEADBAND:2

Defines the deadband for alarm 2.

(R) 1 to 9999

(D) 2

12. RELAY:2

Defines the state of the relay in the alarm condition for alarm 2.

- (D) RELAY ON
- RELAY OFF

13. LATCHING:2

Defines the latching sequence of alarm 2.

- (D) LATCH
- NO LATCH

Software Set Up

14. ACK.:2

Defines whether alarm 2 may be acknowledged.

- (D) **ENABLED** Allows the alarm to be acknowledged
- **DISABLED** Prevents the alarm acknowledgment while alarm condition exists.

ALARMS

ACK.:2

ENABLED

15. POWER UP:2

Defines how alarm 2 will be treated on power up.

- (D) **NORMAL** Alarm depends on process variable
- **ALARM** Always power up in alarm regardless of process variable
 - **DELAYED** Must leave alarm condition and reenter before activating the alarm

POWER UP:2

NORMAL

16. MESSAGE:2

Allows you to enter a nine character message associated with alarm 2. The first character of the 3rd display will be flashing. To enter message, press arrow keys to scroll through character set. Press **FAST** key to enter the selection and move to next digit. Press **MENU** key to advance to next parameter.

- (D) **ALARM 2**

MESSAGE:2

ALARM 2

17. RATE TIME

Defines the time period in seconds over which a rate-of-change alarm condition will be determined.

- (R) 1 to 3600
- (D) 5
- (R) -9999 to 99999
- (D) Dependent on the process variable range

RATE TIME

5

Escape to Operation Mode

DISPLAY

Next Parameter

MENU

Next Block

≡FAST

+

MENU

Next value

▲

OR

▼

SECURITY

SECURITY

SEC. CODE

0

REM./LOCAL

UNLOCKED

LOCAL OUT

UNLOCKED

ALARM ACK.

UNLOCKED

OPERATION

UNLOCKED

CONFIGURE

UNLOCKED

SER.COMM.

STATION

1

SECURITY

For configuring the security function.

1. **SEC. CODE**
Defines security code for temporarily unlocking the station.
(R) -9999 to 99999
(D) 0
2. **REM./LOCAL**
Defines lockout status of the **LOCAL** key.
(D) UNLOCKED
 - LOCKED
3. **LOCAL OUT**
Defines lockout status of the ▲ and ▼ keys for changing the output.
(D) UNLOCKED
 - LOCKED
4. **ALARM ACK.**
Defines the lockout status of the **ACK** key.
(D) UNLOCKED
 - LOCKED
5. **OPERATION**
Defines lockout status of the operations parameters.
(D) UNLOCKED
 - LOCKED
6. **CONFIGURE**
Defines lockout status of the configuration parameters.
(D) UNLOCKED
 - LOCKED

SER. COMM.

For configuring the serial communications features.

1. **STATION**
Defines the unit's station address.
(R) 1 to 99
• OFF disables the communications function
(D) 1

Escape to Operation Mode

DISPLAY

Next Parameter

MENU

Next Block

≡FAST

+

MENU

Next value

▲

OR

▼

Software Set Up

2. BAUD RATE

Defines the baud rate.

- 1200 BPS
- 2400 BPS
- 4800 BPS
- (D)** 9600 BPS
- 19200 BPS

SER.COMM.

BAUD RATE

9600

3. CRC

Defines whether CRC (cyclic redundancy check) is being calculated.

- (D)** YES
- NO

CRC

YES

OPERATION

For modifications to the transition functions.

1. HOST. BREAK

Selects the output value upon loss of the host CV signal.

- (D)** LAST
- PRESET 1
- PRESET 2

HOST BREAK

LAST

2. R/L XFER

Selects the output change algorithm for a **Remote** to **Local** mode transfer.

- (D)** DIRECT
- RAMP

R/L XFER

DIRECT

3. R/L RAMP

Selects the output change time (ramp rate) for a **Remote** to **Local** mode transfer.

- (R)** 5 seconds to 120 seconds
- (D)** 10 seconds

R/L RAMP

10

4. HOST.RESTR.

Selects the controller mode upon restoration of the host CV signal.

- REMOTE
- (D)** LOCAL

HOST.RESTR.

LOCAL

5. L/R XFER

Selects the output change algorithm for a **Local** to **Remote** mode transfer.

- (D)** DIRECT
- RAMP

L/R XFER

DIRECT

Escape to Operation Mode

DISPLAY

Next Parameter

MENU

Next Block

≡FAST

+

MENU

Next value

▲

OR

▼

OPERATION

L/R RAMP

10

PRESET 1

0.0

PRESET 2

100.0

6. L/R RAMP
Selects the output change time (ramp rate) for a **Local** to **Remote** mode transfer.
(R) 5 seconds to 120 seconds
(D) 10 seconds
7. PRESET 1
Selects output value for the 1st preset.
(R) -5.0% to 105.0%
(D) 0.0%
8. PRESET 2
Selects output value for the 2nd preset.
(R) -5.0% to 105.0%
(D) 100.0%

Escape to Operation Mode

DISPLAY

Next Parameter

MENU

Next Block

≡FAST

+

MENU

Next value



OR



SOFTWARE SET UP CHARTS

Record the values for the various Set Up parameters in this section. You may want to photocopy these pages instead of entering the values on the master sheets.

CONFIG.

	PARAMETER	DESCRIPTION	VALUE
1	INDICATOR	Enables indicator and/or 2nd input	
2	2ND INPUT	Chooses type of 2nd input	
3	LINE FREQ	Chooses power source frequency	
4	OUTPUT 1	Defines function of 1st output	
5	CONTACT 1	Operation of 1st digital input	
6	CONTACT 2	Operation of 2nd digital input	
7	CONTACT 3	Operation of 3rd digital input	
8	STN.NAME	Message for naming the station	

LOCAL OUT.

	PARAMETER	DESCRIPTION	VALUE
1	LOW LIMIT	Lowest adjustable output value	
2	HIGH.LIMIT	Highest adjustable output value	
3	PWR.UP:MODE	Selects power-up mode	
4	PWR. UP: OUT	Selects power-up output in local mode	

PV INPUT

	PARAMETER	DESCRIPTION	VALUE
1	PV TYPE	Sensor type selection	
2	DEG. F/C/K	Temperature engineering unit	
3	DECIMAL	Decimal point position	
4	LINEARIZE	Type of input linearization	
5	LOW RANGE	Engineering unit for lowest input value	
6	HI RANGE	Engineering unit for highest input value	
7	FILTER	Setting for the low pass input filter	
8	PV OFFSET	Offset to the PV in engineering units	
9	PV GAIN	Gain to the PV	

CUST. LINR.

	PARAMETER	DESCRIPTION	VALUE
1	1ST. INPUT	Input signal corresponding to 1st point	
2	1ST. PV	Eng.unit value corresponding to 1st point	
3	2ND. INPUT	Input signal corresponding to 2nd point	
4	2ND. PV	Eng.unit value corresponding to 2nd point	
5	3RD. INPUT	Input signal corresponding to 3rd point	
6	3RD. PV	Eng.unit value corresponding to 3rd point	
7	4TH. INPUT	Input signal corresponding to 4th point	
8	4TH. PV	Eng.unit value corresponding to 4th point	
9	5TH. INPUT	Input signal corresponding to 5th point	
10	5TH. PV	Eng.unit value corresponding to 5th point	
11	6TH. INPUT	Input signal corresponding to 6th point	
12	6TH. PV	Eng.unit value corresponding to 6th point	
13	7TH. INPUT	Input signal corresponding to 7th point	
14	7TH. PV	Eng.unit value corresponding to 7th point	
15	8TH. INPUT	Input signal corresponding to 8th point	
16	8TH. PV	Eng.unit value corresponding to 8thpoint	
17	9TH. INPUT	Input signal corresponding to 9th point	
18	9TH. PV	Eng.unit value corresponding to 9th point	
19	10TH. INPT.	Input signal corresponding to 10th point	
20	10TH. PV	Eng.unit value corresponding to 10th point	
21	11TH. INPT.	Input signal corresponding to 11th point	
22	11TH. PV	Eng.unit value corresponding to 11th point	
23	12TH. INPT.	Input signal corresponding to 12th point	
24	12TH. PV	Eng.unit value corresponding to 12th point	
25	13TH. INPT.	Input signal corresponding to 13th point	
26	13TH. PV	Eng.unit value corresponding to 13th point	
27	14TH. INPT.	Input signal corresponding to 14th point	
28	14TH. PV	Eng.unit value corresponding to 14th point	
29	15TH. INPT.	Input signal corresponding to 15th point	
30	15TH. PV	Eng.unit value corresponding to 15th point	

SP INPUT

	PARAMETER	DESCRIPTION	VALUE
1	SP TYPE	Type of input signal for setpoint indicator	
2	SP LOW	Eng. unit value for lowest SP input value	
3	SP HIGH	Eng. unit value for highest SP input value	
4	SP DISPLAY	How to display SP (SP or deviation from PV)	

VP INPUT

	PARAMETER	DESCRIPTION	VALUE
1	VP TYPE	Type of input signal for VP indicator	
2	VP LOW	Eng. unit value for lowest VP input value	
3	VP HIGH	Eng. unit value for highest VP input value	

ALARMS

	PARAMETER	DESCRIPTION	VALUE
1	ALM. TYPE:1	Type of alarm for alarm 1	
2	ALARM SP:1	Alarm 1 setpoint	
3	DEADBAND:1	Deadband for alarm 1	
4	RELAY:1	State of the relay for alarm 1	
5	LATCHING:1	Latching sequence of alarm 1	
6	ACK. :1	Whether alarm 1 may be acknowledged	
7	POWER UP:1	Treatment of alarm 1 upon power up	
8	MESSAGE:1	Message for alarm 1	
9	ALM. TYPE:2	Type of alarm for alarm 2	
10	ALARM SP:2	Alarm 2 setpoint	
11	DEADBAND:2	Deadband for alarm 2	
12	LATCHING:2	Latching sequence of alarm 2	
13	RELAY:2	State of the relay for alarm 2	
14	ACK. :2	Whether alarm 2 may be acknowledged	
15	POWER UP:2	Treatment of alarm 2 upon power up	
16	MESSAGE:2	Message for alarm 2	
17	RATE TIME	Time that determines rate-of-change alarm	

SECURITY

	PARAMETER	DESCRIPTION	VALUE
1	SEC. CODE	Security code to temporarily unlock station	
2	REM./LOCAL	Lockout of LOCAL key	
3	LOCAL OUT	Lockout of ▲/ ▼ keys (no changes to output)	
4	ALARM ACK.	Lockout of ACK key	
5	OPERATION	Lockout of OPERATIONS parameters	
6	CONFIGURE	Lockout of CONFIGURATION	

SER. COMM.

	PARAMETER	DESCRIPTION	VALUE
1	STATION	The unit's station address	
2	BAUD RATE	The baud rate	
3	CRC	Whether to calculate the CRC	

OPERATIONS

	PARAMETER	DESCRIPTION	VALUE
1	HOST. BREAK	Output choice if host CV signal is lost	
2	R/L XFER	R-to-L transfer output change type	
3	R/L RAMP	R-to-L transfer output change time	
4	HOST. RESTR.	Mode when CV signal is restored	
5	L/R XFER	L-to-R transfer output change type	
6	L/R RAMP	L-to-R transfer output change time	
7	PRESET 1	Output value for 1st preset	
8	PRESET 2	Output value for 2nd preset	

CHAPTER 6

APPLICATIONS

The 532 has a variety of user-programmable control features and capabilities. This chapter describes their applications.

532 Auto/Manual Station	41
Alarm Set Up	42
Digital Inputs	47
Process Variable, Setpoint and Valve Position Indication	48
Input Linearization	49
Ramp to Control Value	52
Security	52
Process Variable Reading Correction	53
Serial Communications	54

NOTE:

Available capabilities depend upon the hardware option you specified and ordered.

NOTE:

In this chapter, the following abbreviations are used:

CV - Control signal

SP - Set point

VP - Valve Position

PV - Process Variable

532 Auto/Manual Station

The 532 Auto/Manual Station provides automatic and manual control backup for critical control loops. It is normally installed between a **Host** device and the final control element. The **Host** may be a PLC, DCS or single loop controller (SLC). The final control element may be a valve actuator, positioning device, power control unit for an electric heating element, pump or other control device. The control signal must always be a 4-20mA proportional signal.

A. HOST Mode (Default Mode)

1. In the **Host mode**, the 532 is transparent to the control loop; it passes the control signal from the **Host** device without any degradation.
2. The 532 constantly monitors the CV and uses the last good signal as a potential CV for the transition mode.
3. In **Host mode**, the 532 can be removed from the case without disrupting the **Host** signal; it is not a point of failure.

B. Transition Mode to LOCAL

1. The 532 switches to **Local mode** due to:
 - a. Loss of the **Host** signal
 - b. Keypad selection
 - c. Closure of a digital contact; or
 - d. Commands through the RS-485 port.
2. Upon switching to **Local**, the 532 generates a control signal based on the last known CV from the **Host**, or selects one of two predetermined CV(s).

Escape to Operation Mode	DISPLAY	Next Parameter	MENU	Next Block	≡FAST	+	MENU	Next value	▲	or	▼
--------------------------	---------	----------------	------	------------	-------	---	------	------------	---	----	---

3. The 532 can ramp the last **Host** signal value to either of the predetermined CV value(s).
4. In **Local mode**, the operator can modify the CV signal using ▲ and ▼ keys.

C. Transition Mode to HOST Mode

1. The 532 returns to **Host Mode** due to:
 - a. Return of **Host** signal (if configured to do so);
 - b. Keypad selection;
 - c. Digital contact; or
 - d. Commands through the RS-485 port.
2. Upon return of the **Host** signal, the 532 can be programmed to
 - a. Return control to the **Host** immediately;
 - b. Ramp to the new CV at a predetermined rate; or
 - c. Remain in **Local mode**. In **Local mode**, the operator can determine whether or not the **Host** signal is valid.

Alarm Set Up

The 532 has 2 available alarms. It indicates alarm conditions by:

- Lighting up the alarm icon(s).
- Displaying a custom message in the 3rd display
- Illuminating the **ACK** key if the alarm is acknowledgeable.

On the 532, you assign one of 6 different types to each alarm. Also, by adding an output module, one of the alarms can be tied a relay output.

A. Set the Alarm Type.

1. Press **FAST + MENU** to toggle to the **ALARM** menu.
2. Press **MENU** to select the first parameter ALM.TYPE:1 and select its type (choose one of the following) using the ▲ and ▼ keys:

LOCAL

If tied to a relay output, a Local alarm notifies the **Host** that the 532 has taken over manual control. You can choose LOCAL for only one of the 532 alarms. This alarm is useful when the **Host** performs logging functions for Statistical Process Control (SPC), or to prevent reset windup.

HIGH ALARM.

The high process variable alarm occurs when the process variable exceeds the alarm setpoint.

LOW ALARM

The low process variable alarm occurs when the process variable goes below the alarm setpoint.

NOTE:

Refer to Chapter 4 for information on wiring for alarms.

NOTE:

Refer to Chapter 2 for information on operating alarms.

Escape to Operation Mode	DISPLAY	Next Parameter	MENU	Next Block	≡FAST	+	MENU	Next value	▲	or	▼
--------------------------	---------	----------------	------	------------	-------	---	------	------------	---	----	---

BAND

The band alarm creates a band twice the size of the alarm setpoint [centered] around the control setpoint. An alarm occurs when the process variable travels outside of this band. For example, if your control setpoint is 500 and the band alarm setting is 25, the alarm occurs if the PV travels outside of the 475 to 525 range.

This alarm is dependent upon retransmission of the control setpoint to the 532. As the control setpoint changes, the band changes accordingly.

DEVIATION

The deviation alarm creates a band on one side of the control setpoint. An alarm occurs when the process variable deviates from the control setpoint by an amount greater than the alarm setpoint.

For example, if the control setpoint is 500 and the alarm setpoint is +50 (plus 50), an alarm occurs when the process variable exceeds 550. If your alarm setpoint is -50, the alarm occurs when the process variable drops below 450.

This alarm is dependent upon retransmission of the control setpoint to the 532. As the control setpoint changes, the band changes accordingly.

NOTE:

The Band and Deviation alarms are not selectable without a PV and a retransmitted SP signal.

RATE

The rate alarm occurs when the process variable changes at a rate greater than that specified by the alarm setpoint and time base. For example, if you have an alarm setpoint of 10 and a time base of 5 seconds, an alarm occurs if the VP changes greater than 10 in 5 seconds.

Use RATE to signal an alarm before the PV reaches an undesirable level.

3. Press the **MENU** key to select the second parameter ALM.TYPE:2 and select its type using the ▲ and ▼ keys.

B. Set the Alarm Parameters

Each **alarm type** (except the 532 LOCAL alarm) has a number of corresponding parameters that must also be set up in the **ALARM** menu.

Smart Menus feature: only those parameters that apply to your particular alarm type will appear as you toggle through the parameters.

Press the **MENU** key to select the rest of the parameters in the **ALARM** menu, and choose their values with the ▲ and ▼ keys.

4. ALARM SP:1 and ALARM SP:2

Specifies, in engineering units, the point at which the alarm occurs.

For a rate-of-change alarm, it specifies the amount of change that must occur before the alarm activates. A negative value specifies a negative rate-of-change.



5. DEADBAND:1 and DEADBAND:2
Specifies the range through which the PV must travel before leaving an alarm condition (see alarm examples at the end of this section).
This prevents frequent alarm oscillation or “chattering” if the process variable has stabilized around the alarm point.
6. RELAY:1 and RELAY:2
Specifies whether the relay will be on or off. ON means the relay is energized, while OFF means the relay is de-energized when the station is in the alarm condition.
Most applications require the relay to energize. However, limit applications usually require the relay to de-energize.
7. LATCHING:1 and LATCHING:2
If the alarm is latching (YES), the alarm remains active after leaving the alarm condition unless acknowledged.
If the alarm is non-latching (NO) the alarm returns to its non-alarm state when leaving the alarm condition without being acknowledged.
8. ACK.:1 and ACK.:2
ENABLED allows the operator to acknowledge an alarm at any time, even if the control process is still in the alarm condition.
DISABLED prevents the operator from acknowledging an alarm while the process is in the alarm condition.
When either alarm is available to be acknowledged, the **ACK** key will be illuminated. If both alarms are acknowledgeable, press the **ACK** key once to acknowledge alarm #1, then a second time for alarm #2. A latching alarm can always be acknowledged when it is out of the alarm condition.
9. POWER UP:1 and POWER UP:2
If you want the controller to always power up in alarm, regardless of the alarm condition, then select ALARM. This is an excellent way to activate an alarm if there has been a power failure.
If you never want the controller to power up in alarm, regardless of alarm condition, select DELAYED. The system must leave and reenter the alarm condition before the alarm will activate. This is typically used to avoid alarms during start up.
If you want the system to power up in alarm only if it is in an alarm condition, select NORMAL.
10. MESSAGE:1 and MESSAGE:2
Allows you to enter a nine character message to display when the respective alarm is active. The first character of the 3rd display will be flashing. Use ▲ and ▼ keys to scroll through character set for each character Press **FAST** to enter the selection and move to next digit. Press **MENU** to advance to next parameter.

NOTE:

You can specify whether the relay is Normally Open or Normally Closed when configuring the hardware, with jumper selection for outputs 1, 2 & 3.

Escape to Operation Mode	DISPLAY	Next Parameter	MENU	Next Block	≡FAST	+	MENU	Next value	▲	or	▼
--------------------------	---------	----------------	------	------------	-------	---	------	------------	---	----	---

11. RATE TIME

Defines the time period over which a specific change in process variable must occur for the rate alarm to be activated. The amount of change is defined by the alarm setpoint. The rate-of-change is defined as the amount of change divided by the time period. In general, for a given rate-of-change, the shorter the time period, the more sensitive the rate alarm.

Example:

- a. If the alarm setpoint is set to 10 and the time base is set to 1 second, the rate of change is 10 units per second. The process variable would only have to experience a ten unit change over a short period of time.
- b. If the alarm setpoint is set to 100 and the time base set to 10, the rate of change is also 10 units per second. The PV would require a 100 unit change over a ten second period.

Notice that Example A is more sensitive than Example B.

For graphic examples of alarm applications, see next page.



Applications

Figure 6.1
Alarm Examples

Alarm Examples

A.SP - Alarm Setpoint C.SP = Control Setpoint
DB = Deadband PV = Process Variable

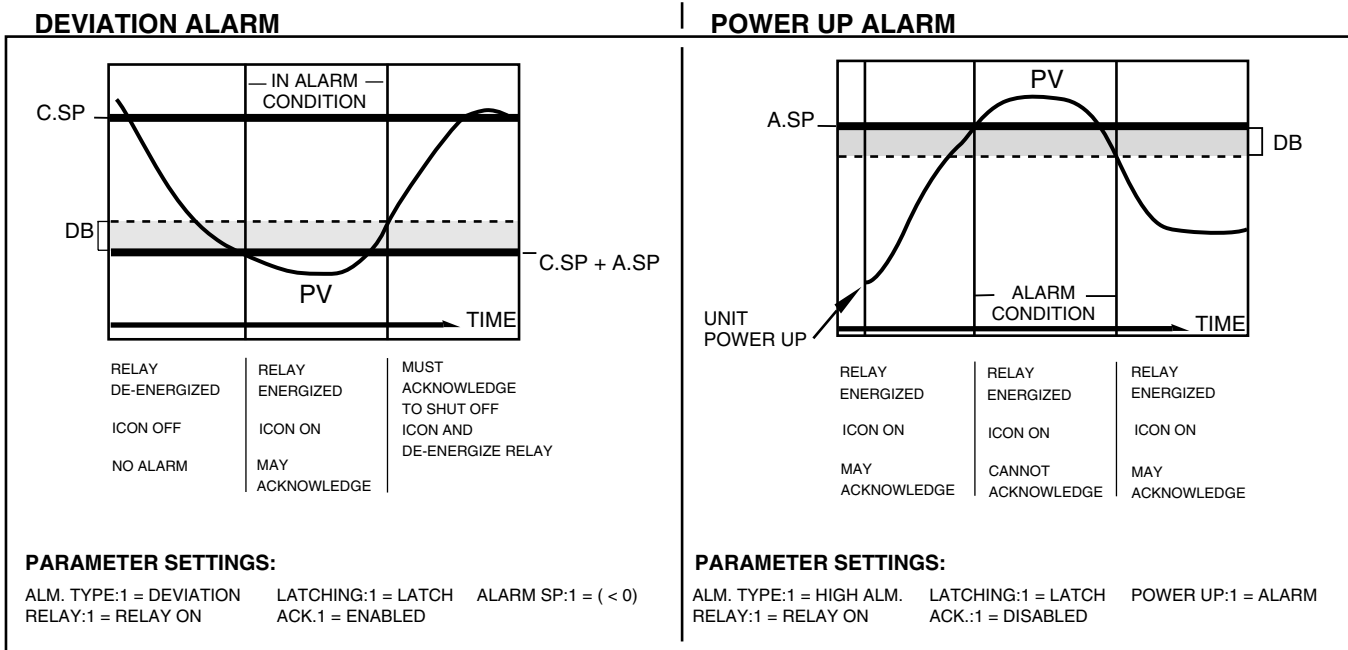
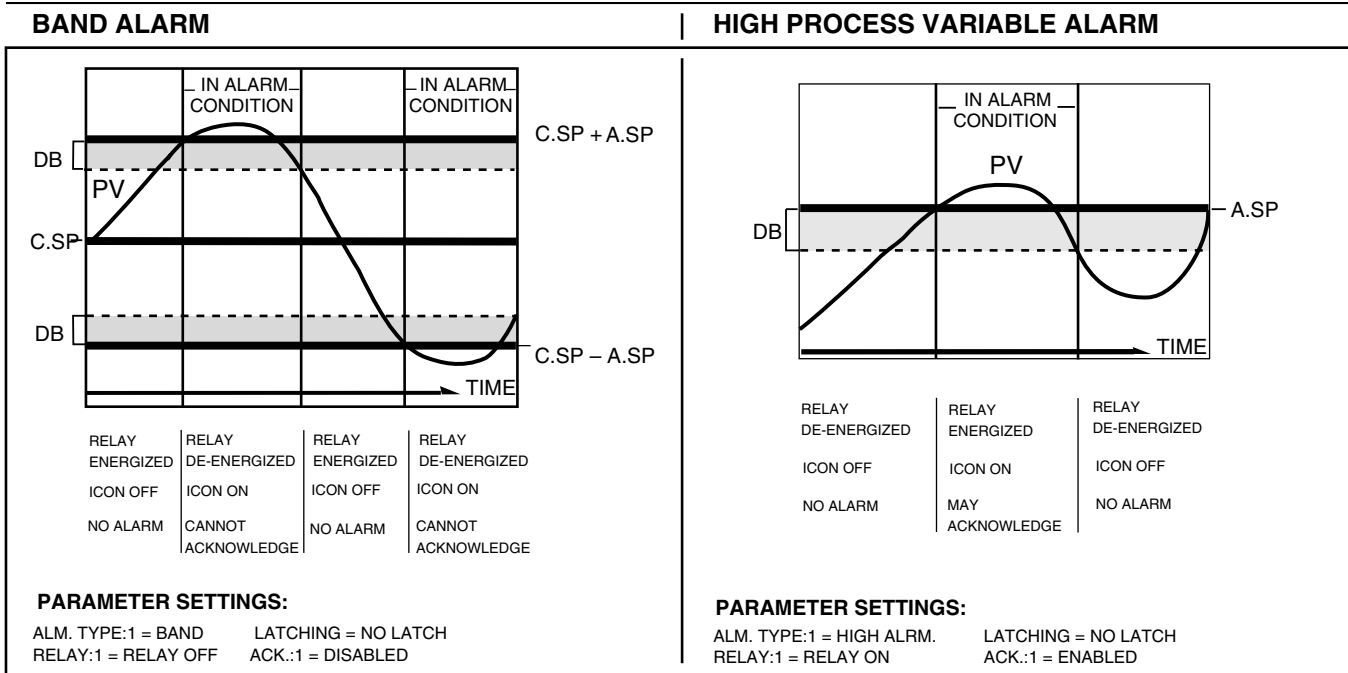

Escape to Operation Mode DISPLAY Next Parameter MENU Next Block ≡FAST + MENU Next value ▲ or ▼

Digital Inputs

This optional feature is only available if ordered originally from the factory. For a set of 3 digital inputs can be ordered, order Product #532 -xxxxxxDx00. If more than one digital input is closed, then the last one closed generally has priority over the others.

A closed digital input may be overridden by: another digital input, a keyboard operation, or an automatic function. A closed digital input that was overridden must be opened, in order to be “rearmed”.

If one digital input is closed and selects the LOCAL, and then REMOTE is keyboard selected, the keyboard selection takes precedence.

1. Press **FAST + MENU** to toggle to the **CONFIG**. menu.
2. Press **MENU** to access first parameter, CONTACT:1. Use ▲ and ▼ to toggle to the desired function (choose one of the following):

ALARM ACK.

Upon contact closure, all active alarms are acknowledged. The digital input must be opened before it is “rearmed”. If the input remains closed, it does not continue to immediately acknowledge alarms as they become active.

UP KEY and DOWN KEY

Contact closure mimics the ▲ and ▼ keys. If the station is mounted behind a window, this digital input allows you to use momentary contact push button to change the station’s output.

COMM. ONLY

Renders digital input status readable through communications. It will have no effect on the functions of the station itself.

LOCAL.LAST

Upon contact closure the station switches to **Local mode** and uses the last good control value (CV) from the **Host** as its output.

LOCAL.PRE1

Upon contact closure the station switches to local mode and uses preset output value #1 as the output control value.

LOCAL.PRE2

Upon contact closure the station switches to local mode and uses preset output value #2 as the output control value.

OUT LOCK

Upon contact closure the station switches uses the LOCKED OUT. value as the CV and prevents changing it from the keypad.

3. Press **MENU** to access second and third parameters, CONTACT:2 and CONTACT:3. Use the ▲ and ▼ keys to toggle to the desired function for these as well (choose one of the following).



Process Variable, Setpoint and Valve Position Indication

The 532 can be set up to display the process variable. This can be a direct input of a thermocouple, RTD, mA or voltage signal. Milliamp and voltage signal can be displayed as 0-100% or scaled in Engineering units. Custom linearization is also available.

A. Choose the Type of Display(s)

You need to define what indicators you want to display: NONE, the PV, the SP, the VP, the PV and the SP or the PV and the VP.

Because the 532 can show two values at once, the operator has complete information concerning the **Host** device; this eliminates the need for other indicators. By tying these features to the 532 alarm capability, the operator may establish alarms independent of the **Host** system.

1. Press **FAST + MENU** to toggle to the **CONFIG.** menu.
2. Press **MENU** to access the INDICATOR parameter. Use ▲ and ▼ to choose the indicator display: NONE, PV, 2ND (activated 2nd second input) or PV/2ND (both PV and 2ND input).
3. Press **MENU** to access the 2ND INPUT parameter. Use ▲ and ▼ to choose the 2ND type of indicator display: VP or SP.

See Chapter 2 for information about displaying and adjusting the CV.

B. Select the Process Variable Display Range

1. Press the **FAST + MENU** keys to toggle to the **PV INPUT** menu. Press **MENU** to access the following parameters, and use the ▲ and ▼ keys to assign values.
2. PV TYPE
Defines the range of the input signal (T/C, RTD, mA or voltage signal). The type of signal is governed by the hardware jumper selections (see Chapter 3).
3. DEG. F/C/K
Selects the units for temperature display (appears only for T/C and RTD input types).
4. DECIMAL
Sets the position of the decimal point (appears only for V/mA and RTD input types).
5. LINEARIZE
Selects the type of PV linearization being used (appears only for V/mA input types).
6. LOW RANGE
Sets the value in engineering units corresponding to the low PV input value (appears only for v/mA input types).

NOTE:

Please see Chapter 3 or proper jumper settings for the PV and SP/VP.

Escape to Operation Mode	DISPLAY	Next Parameter	MENU	Next Block	≡FAST	+	MENU	Next value	▲	or	▼
--------------------------	---------	----------------	------	------------	-------	---	------	------------	---	----	---

7. HI RANGE
Sets the value in engineering units corresponding to the high PV input value (appears only for V/mA inputs types).
8. FILTER
Sets the amount of PV filtering to be used.
9. PV OFFSET
Sets a constant offset to be applied to the PV input.
10. PV GAIN
Sets a constant gain to be applied to the PV input (appears only for V/ mA input types).

C. Set Point Display Range

The 532 can be set up to display a retransmitted setpoint from the **HOST** device. This is a powerful feature when the PV indicator option is also used.

1. Press **FAST + MENU** to toggle to the **SP INPUT** menu. Press **MENU** to access the following parameters, and use ▲ and ▼ to assign values.
2. SP TYPE
Defines the input signal range. (0 - 20mA or 4 - 20mA).
3. SP LOW and SP HIGH
These define the range of the set point in engineering units. The correct range will be dependent on the source of the set point signal.
4. SP.DISPLAY
Selects whether to display SP as an actual SP (SET POINT) or as a deviation from PV (DEVIATION). This function appears only if both PV and SP indicators are enabled.

D. Valve Position Display Range

The 532 can be set up to display a retransmitted valve position from the **HOST** device.

1. Press **FAST + MENU** to toggle to the **VP INPUT** menu. Press **MENU** to access the following parameters, and use ▲ and ▼ to assign values.
2. VP TYPE
Defines the input signal range. (0 - 20mA or 4 - 20mA).
3. VP LOW and VP HIGH
These define the range of the valve position in engineering units. The correct range will be dependent on the source of the set point signal.

Input Linearization

A. Thermocouple and RTD Linearization

When you select a thermocouple or RTD input, the station automatically linearizes the incoming signal. The station uses internal lookup tables to provide an accurate reading of the temperature being sensed.



B. Square Root Linearization

Many flow transmitters generate a nonlinear signal corresponding to the flow being measured. The station must have the square root of this signal in order to use it. The station has the capability to perform this function for itself.

To utilize this feature, you must have a voltage or milliamp input.

1. Press **FAST + MENU** to toggle to the **PV INPUT** menu.
2. Press **MENU** to access the LINEARIZE parameters, and use the ▲ and ▼ keys to assign value SQR. ROOT.

For the first 1% of the input span, the input is treated in a linear fashion. After that, it is a value calculated using the formula in Figure 6.2:

$$PV = \text{Low Range} + [(\text{Hi Range} - \text{Low Range}) \sqrt{(V_{\text{input}} - V_{\text{low}}) / (V_{\text{high}} - V_{\text{low}})}]$$

Where: Hi Range is the high end of the process variable.
 Low Range is the low end of the process variable.
 V_{input} is the actual voltage or current value of the input.
 V_{high} is the high end of the input signal range (e.g. 5 volts or 20 mA).
 V_{low} is the low end of the input signal range (e.g. 1 volt or 4 mA).

Example: Process variable range is 0 – 1000.
 Input signal range is 1–5 volts
 Input signal is 3 volts.
 Therefore, the PV will be—

$$PV = 0 + [(1000 - 0) \sqrt{(3-1) / (5-1)}] = 1000 \sqrt{.5} = 707$$

Figure 6.2
Square Root Linearization Formula

C. Custom Linearization

Custom linearization allows you to take virtually any nonlinear signal and linearize it using a 15-point straight line approximation curve (see Figure 6.3). Typical applications are linearizing signals from nonlinear transducers, or controlling volume based on level readings for irregularly-shaped vessels. To define the function, you must enter data point pairs—the engineering units corresponding to a particular voltage or current input.



Figure 6.3
Custom Linearization Curve

NOTE:

The resulting linearization curve must be either ever-increasing or ever-decreasing.

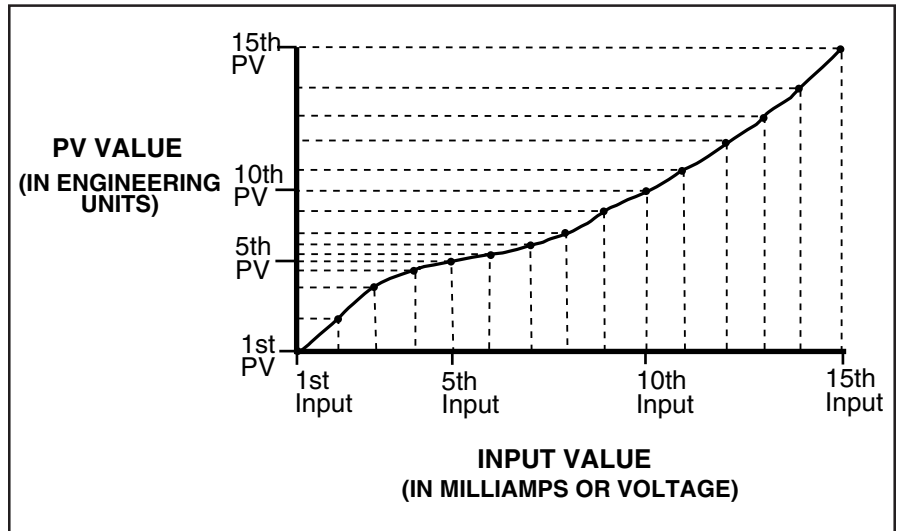

NOTE:

If you make any modifications to a set curve, **you must re-enter all points in order**, from 1 to X. Use the Set Up Charts in Chapter 5 to record your data.

1. Press **FAST + MENU** to toggle to the **INPUT** menu.
2. Press **MENU** to access the LINEARIZE parameters, and use the ▲ and ▼ keys to assign value CUSTOM.
3. Press **FAST + MENU** to toggle to the **CUST.LINR.** menu.
4. The parameter 1ST INPUT is fixed at the low end of the mA or Voltage input range.
5. For parameter 1ST PV, define the corresponding process variable value in engineering units.
6. For 2ND INPUT, 3RD INPUT...15TH INPUT, define the milliamp or voltage input of the corresponding data point.
7. For the 2ND PV, 3RD PV...15TH PV, define the corresponding process variable value in engineering units.

Once the various points are defined, the station interpolates the values between the points using a straight line relationship between them.

Escape to Operation Mode	DISPLAY	Next Parameter	MENU	Next Block	≡FAST	+	MENU	Next value	▲	OR	▼
--------------------------	---------	----------------	------	------------	-------	---	------	------------	---	----	---

Ramp to Control Value

The “ramp to control value” function is especially useful in processes where the rate-of-change (from **Remote to Local**, or **Local to Remote**) of the control value must be limited, or under any circumstances where there is likely to be a significant difference between control values at mode transition time.

Under normal operating circumstances, the 532 passes the **Host** device signal to the final control element without modification, and stores the current CV value with each cycle of the CPU. When the 532 switches to **Local mode** (see page 2 for details), it will provide a CV based on the last known good value from the **Host**. It can also, however, go to one of two preset outputs. These values may be considerably different from the **Host** value, so a sudden change in the output value is possible. The ramp feature enables the operator to select how long it will take the output to change from one value to the other. The 532 has provisions for ramping from **Remote to Local**, and from **Local to Remote**.

1. Press the **FAST + MENU** keys to toggle to the **OPERATIONS** menu.
2. For **Remote to Local mode** transfer, set the parameter R/L XFER (remote to local transfer type), to type RAMP.
2. For **Local to Remote mode** transfer, set the parameter L/R XFER (local to remote transfer type) to type RAMP.
3. Either the R/L RAMP (remote to local ramp) parameter and/or L/R RAMP (local to remote ramp) will now be available. Enter the transition time (5-120 seconds).

When this function is active the controller will automatically ramp the control value at the desired rate during the transition from remote to local control or local to remote control. It will also work if preset values have been chosen when transferring between remote and local control.

Security

The security function contains parameters that allow the user to selectively lock out the various functions of the station. Security only locks out the keypad commands. Digital Inputs or Serial Communications are not affected.

1. Press the **FAST + MENU** keys to toggle to the **SECURITY** menu. Press **MENU** to access each of the following parameters, and the ▲ and ▼ keys to set their values.
2. SEC. CODE
Define the security code using the ▲ and ▼ keys. This parameter does not appear unless all functions are unlocked. The security function is compromised if the security code is left at zero (0).
3. REMOT./LOCL
Selects whether the LOCAL key should be LOCKED or UNLOCKED. This function would prevent the operator from placing the 532 in **Local mode**. Transfer to **Local mode** is accomplished by loss of **Host** signal, digital contact closure or Serial Communications only.

NOTE:

Be sure to set the SEC. CODE before locking any other feature. The station will not display this parameter if any others have been LOCKED. You would have to unlock all other parameters in order to view the SEC. CODE again.

Escape to Operation Mode	DISPLAY	Next Parameter	MENU	Next Block	≡FAST	+	MENU	Next value	▲	or	▼
--------------------------	---------	----------------	------	------------	-------	---	------	------------	---	----	---

4. LOCAL OUT

Selects whether the raise and lower keys should be LOCKED or UNLOCKED in **Local mode**. This selection prevents the operator from changing the output value when in **Local mode**.

5. ALARM ACK.

Selects whether the **ACK** key should be LOCKED (to prevent an operator from acknowledging any alarms) or UNLOCKED.

6. OPERATION

Selects whether the operation menu should be LOCKED or UNLOCKED. This selection prevents the operator from accessing the **OPERATION** menu.

7. CONFIGURE

When LOCKED, allows access to the configuration menus, but prevents any unauthorized changes to the configuration parameters. You must lock CONFIGURE if you want full security. If left UNLOCKED, the operator has access to the security code.

Whenever a locked function is attempted, the operator has the opportunity to enter a security code to override the Lock. If the correct code is entered, the operator has full access. The security feature reactivates after one minute of keypad inactivity.

The operator also can enter the SECURITY OVERRIDE CODE, which, if entered correctly, RESETS the whole station to its default settings.

The security override code is **62647**. Store this in a secure place.

Process Variable Reading Correction

Under certain extraneous conditions—such as an aging thermocouple, out of calibration transmitter, lead wire resistance—the station may display values other than the actual process value. To compensate for these conditions, you can set offset and gain values for the process variable.

1. Press **FAST + MENU** to toggle to the **PV INPUT** menu. Press **MENU** to access each of the following parameters, and the ▲ and ▼ keys to set values for them.

2. PV OFFSET

This either adds or subtracts a set value from the process variable reading in engineering units. For example, if your thermocouple was always reading 3° too high, you could set the PV OFFSET parameter to -3 to compensate.

3. PV GAIN

Multiplies the deviation from the low end of the process variable range by the gain factor and then adds it to the value of the low end of the range to arrive at the adjusted process variable value.

NOTE:

The Process Variable Reading Correction feature is provided as a convenience. We recommend that the condition causing the erroneous reading be corrected.

NOTE:

PV GAIN is only available if using a linear voltage or current input.



Example:

If your process variable range is 50 to 650 and the process variable reading is 472, a PV GAIN of 0.995 would yield an adjusted process variable equal to $[(472 - 50) \times 0.995] + 50 = 470$.

By using a combination of both offset and gain factors, you should be able to compensate for just about any inaccuracy in your sensor or transmitter.

Serial Communications

Serial communications is an optional feature. It enables the station to communicate with a supervisory device, such as a personal computer or programmable logic controller. The circuitry for communications is contained on a modular circuit board that plugs into the Microcontroller Circuit Board.

The station uses communications standard RS-485, which provides a multi-drop system that communicates at a high rate over long distances. Typical limitations are 32 stations per pair of wires over a distance up to 4000 feet.

The station uses a proprietary protocol which provides an extremely fast and accurate response to any command. A Cyclic Redundancy Checksum (CRC) can be enabled to ensure the integrity of any data read by the controller. Through communications, you have access to every set up and operating parameter in the station.

1. Press the **FAST + MENU** keys to toggle to the **SER.COMM.** menu. Press **MENU** to access each of the following parameters, and use the ▲ and ▼ keys to set values for them.
2. STATION
Specifies the unit's station address. It is the only way one controller can be distinguished from another. Each controller on the same RS-485 interface must have a unique station address.
3. BAUD RATE
Choose a baud rate from 1200 to 19,200. In general, you want to select the highest baud rate. However, every station on the RS-485 interface must be set to the same baud rate.
4. CRC
Indicates if you are going to take advantage of the Cyclic Redundancy Checksum feature. If your **Host** program supports it, we highly recommend that you activate it.

NOTE:

For further details on the station's communications protocol, contact one of our application engineers.



APPENDIX A MENU & PARAMETER FLOWCHARTS

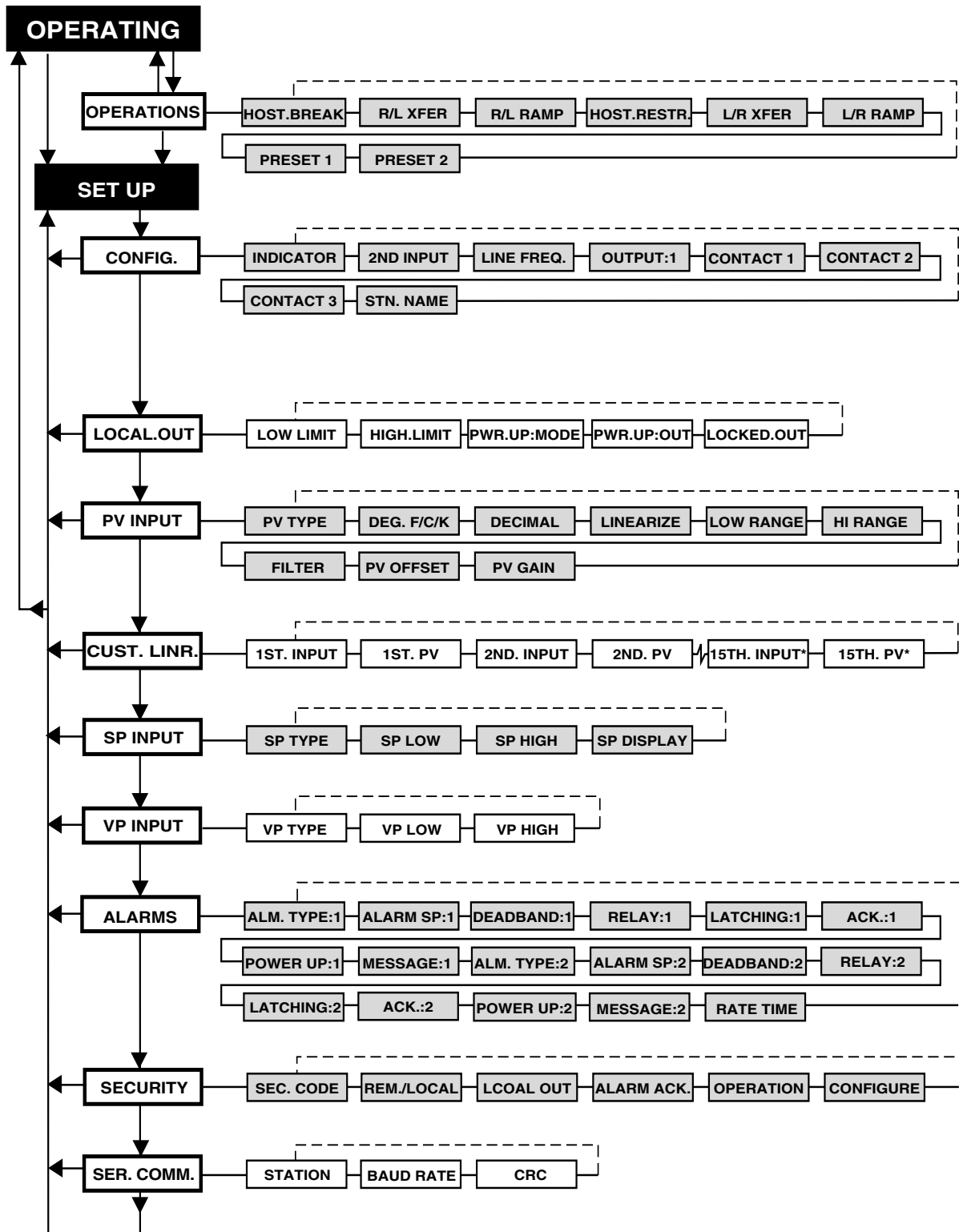

APPENDIX B PARTS LIST

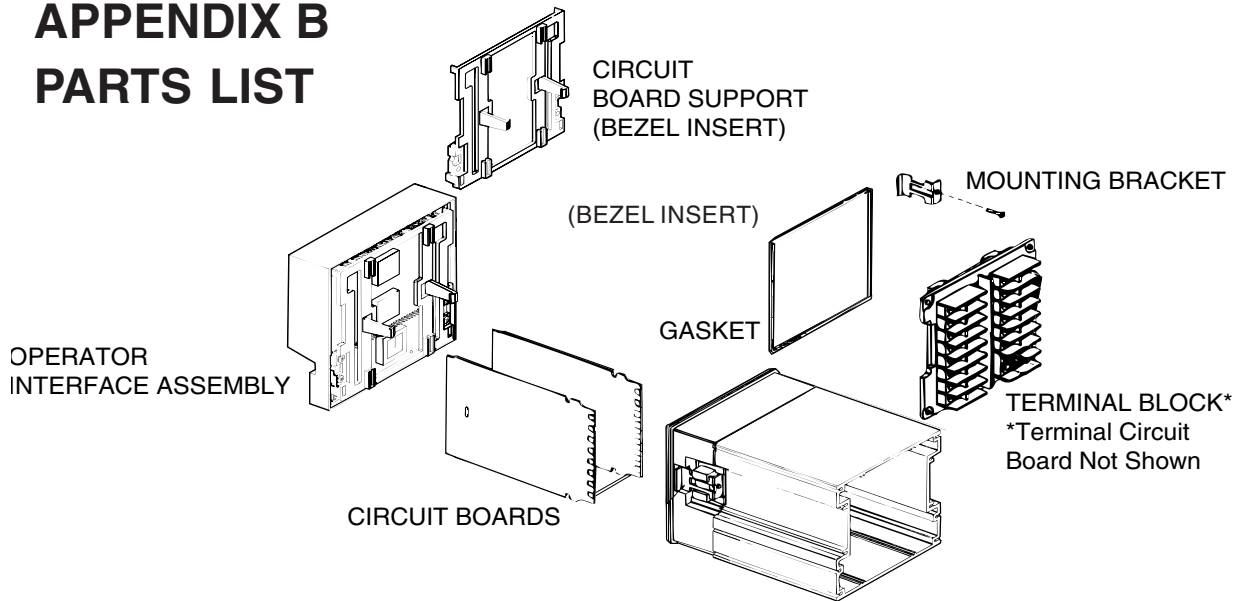

Description	Part #
OUTPUT MODULES	
Mechanical relay module	535 600
532 Analog (mA) module	532 600
Solid State Relay (triac) Module	535 602
DC Logic (solid state relay drive) module	535 603
Loop Power Module	535 604
RS-485 serial communications board	535 605
REPAIR PARTS	
Operator interface assembly 532	532 632
Power supply circuit board	535 630
Microcontroller circuit board 532	535 632
Option circuit board	535 620
Option circuit board w/3 digital inputs 532	532 621
EPROM 532	532 640
Lithium battery	093 128
Jumper kit (set of all jumper connectors)	535 660
Gasket kit (w/panel and bezel gaskets)	535 662

Description	Part #
Mounting kit (including mounting brackets and screws)	535 661
Bezel retention screw kit	535 663
Module retention kit (w/retention plate & tie wrap for outputs 1-3)	535 664
Module retention tie wrap kit (set of 5 tie wraps)	535 665
Terminal block	535 031A
Circuit board support (Bezel Insert)	535 025
Sheet of engineering unit labels	535 106
532 Bypass board	532 100
Goof Plate	512 014

APPENDIX C TROUBLESHOOTING

Message	When does it occur?	What to do:
DEFAULTS	Whenever the memory is cleared and all parameters revert to factory default settings. This may be done by purposely clearing the memory or when the unit is powered up for the first time or if the software version is changed.	Changing any Set Up parameter will clear the message. If due to something other than the user purposely clearing the memory, call factory for assistance.
NEEDS CAL.	Indicates that calibration values are at factory defaults.	Recalibrate the unit
LOST CAL	Indicates that the calibration data has been lost. Occurs when the memory is wiped clean.	Problem should never occur. Must correct the problem, then recalibrate. Call factory for assistance.
ERROR:ROM CHECKSUM	On power up a problem with the ROM is detected. This is a fatal error and requires an EPROM change. Controller locks up until fixed.	Call factory for assistance.
OUT1/CONF	Upon power up, controller senses that the modules needed for control as determined by software configuration are not present.	Must power down and install correct module combination or must reconfigure the controller to match the current module combination.
LOST CJC	If the cold junction is sensed to be lost.	Call factory for assistance.

Troubleshooting

SYMPTOM	PROBLEM	SOLUTION
Display will not light up	Defective power source	Check power source and wiring
	Improper wiring	Correct wiring
	Blown in-line fuse	Check wiring, replace fuse
	Unit not inserted in case properly; or, screws have not been tightened.	Remove unit from case (and remove bezel screws), then reinsert unit and properly tighten screws.
Improper/Lost PV reading • Voltage/current	Input jumper selection improperly set	Move jumper to proper location.
	Input range improperly selected in software	Select proper range
	Reverse polarity	Check and correct sensor wiring
	If station powered up, improperly wired	Check and correct wiring
	If internal supply for transmitter not installed	Install module
	Defective transmitter	Replace transmitter
	Transmitter signal out of range	Select proper range in software
Improper/Lost PV reading • Thermocouple	Defective thermocouple	Replace thermocouple
	Input jumper selection improperly set	Move jumper to proper location.
	Wrong TC type selected in software	Select proper thermocouple type in software
	Improper wiring	Wire properly
Improper/Lost PV reading • RTD	Defective RTD	Replace RTD
	Input jumper selection improperly set	Move jumper to proper location.
	Improper wiring	Wire properly
No control output	Output module not installed	Install proper output modules
	Output wiring and module location do not match	Check and correct wiring or module location
	If SSR, SSR Drive of Milliamp output, jumpers J1, J2 and J3 are not set properly	Move jumper to proper location.
	Software configuration does not match hardware (OUTx CONF. message)	Reconfigure software to match hardware. See OUTx CONF. message.
Can't switch to Host control	Host CV signal is not connected or valid	Check wiring. Check that Host is supplying a valid CV signal.
Erratic display	Resetting action due to electrical noise on powerline	Filter power line.

APPENDIX D CALIBRATION

The first three sections of this chapter provide information on calibration for: **RTD and VmA inputs, Thermocouple Cold Junction Compensation, and Milliamp Output.**

Access these parts of the calibration menu as shown in Figure D.1.

Regarding Calibration

To maintain optimum performance, once a year calibrate the analog input, cold junction (when a thermocouple is used) and mA Out (when used). To achieve published accuracy specifications, follow directions carefully and use calibrated instruments of like quality to those suggested. Also, if you move a station chassis into an alternate case or change its hardware configuration, and you choose to use thermocouple input, you may want to recalibrate the cold junction for optimal accuracy. Failure to do so may result in small junction temperature (not more than 0.6°C/1.1°F).

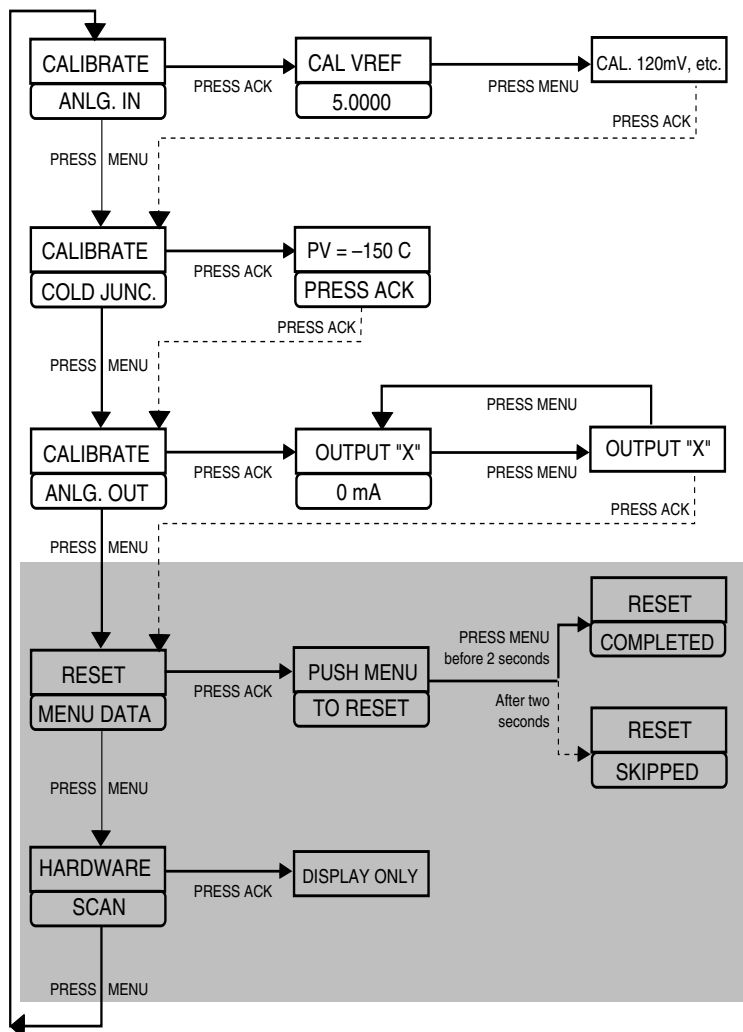

Figure D.1
Flowchart to Access the Calibration
Menus

Before you Begin

! The 532 comes from the factory with one milliamp output module installed in position (output) 2 and relays in position (outputs) 3 and 4. **These must not be modified.** You may install a mechanical relay, solid state relay or DC logic module in position (output) 1 for alarm functions.

! Terminals 1 and 2 carry live power. **Do not touch these terminals when AC power is on.**

RTD, VmA Input Calibration (for indication feature)

Equipment:

- Precision 5-1/2 or 6-1/2 digit multimeter, such as a *Fluke 8842®* or *Hewlett Packard HP3478A®*
- Two small pieces of wire
- Test leads with clips
- #2 Phillips screwdriver

1. Disconnect power to the instrument.
2. Remove chassis from case.

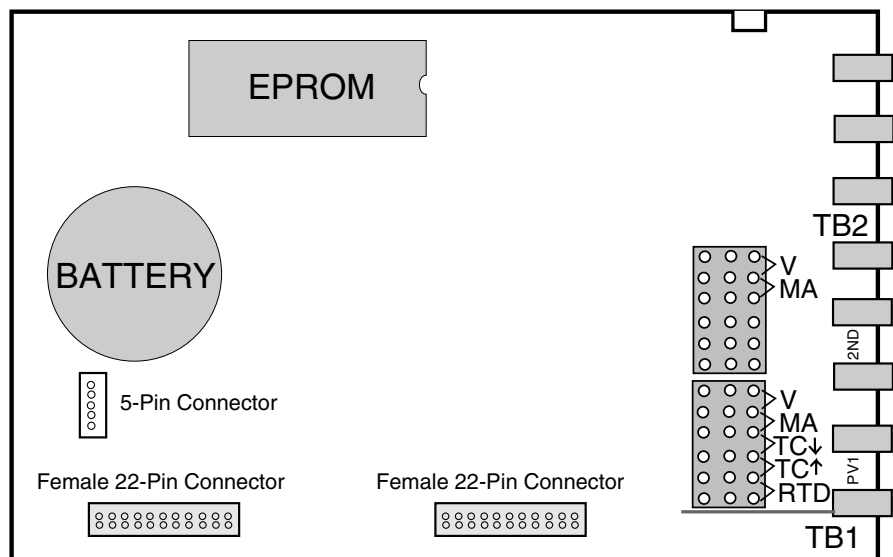

Figure D.2
Microcontroller Circuit Board

3. Locate jumpers locations marked **PV1** and **2nd** near the edge connector of the Microcontroller Circuit Board (Figure D.2). Reposition one of the jumpers on the pins marked **V** of the **2nd** jumper location and the other on the pins marked **TC▲** of the **2nd** jumper location.
4. Connect the hookup wire, as shown in Figure D.3, to terminals 31 and 32. The hookup wire connects to the multimeter. Set the meter for DC volts. Make sure the screws are tight.
5. Reinsert chassis into the case, secure the front panel screws, and apply power. The 2nd display should read CALIBRATE while the 3rd display will read ANLG. IN. **Allow the station and meter to warm up for at least 45 minutes before proceeding.**
6. Press the **ACK** key for the first step in the **ANLG. IN** Menu. The 2nd

WARNING!

ELECTRIC SHOCK HAZARD!

Terminals 1 and 2 carry live power. **Do not touch these terminals when AC power is on.**

display will read CAL. VREF, while the 3rd display will read a value close to 5.0000. Refer to the flowchart in Figure D.1 for guidance.

7. Your meter should read a value between 4.9750 and 5.0250. Press ▲ and ▼ keys on the station until the 3rd display on the station matches your meter's reading. Note that the **FAST** key is active should you decide to use it to move more quickly.
8. Press **MENU**. The 2nd display reads CAL. 120mV and the 3rd display will now read a value close to 120mV. Repeat step 7.
9. Press **MENU** again and repeat this procedure for the remaining voltages (90mV, 60mV, 30mV and 0mV). Each time, you should match the displays of the station and your meter.
10. Continue to press **MENU** if you want to check your settings. Press **ACK** when done. If you will be calibrating milliamp outputs, power down, then up again. Wait at least 5 minutes, then continue on to Milliamp Output Calibration, Step 5. If you are finished calibrating, power down and place the jumpers in their correct operating positions (as specified in Chapter 4).
11. **IMPORTANT!**
You must press ACK at the end of any calibration procedure to return to the calibration menu **before powering down**.

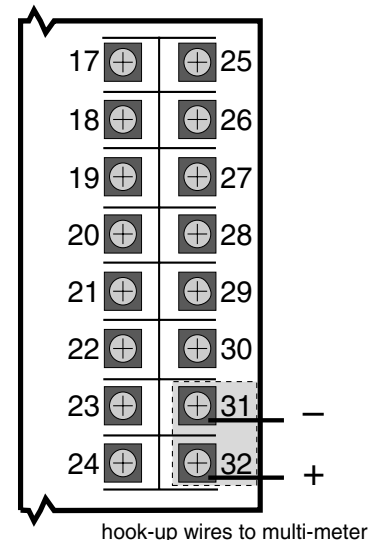

Figure D.3
RTD, VmA Calibration Wiring

Thermocouple & Cold Junction Calibration

(for indication feature)

We recommend that you always perform the input calibration before the cold junction calibration.

Equipment:

- Precision 5-1/2 or 6-1/2 digit multimeter, such as a *Fluke 8842®* or *Hewlett Packard HP3478A®*
- Two small pieces of wire
- Test leads with clips
- #2 Phillips screwdriver
- Precision thermocouple calibrator such as a *Micromite II®* by *Thermo Electric Instruments*
- Type T thermocouple wire (2 pieces), "Special Limits" grade of wire

1. Disconnect power to the instrument.
2. Remove chassis from case.
3. Locate jumpers locations marked **PV1** and **2nd** near the edge connector of the Microcontroller Circuit Board (Figure D.2). Reposition one of the jumpers on the pins marked **V** of the **2nd** jumper location and the other on the pins marked **TC▲** of the **2nd** jumper location.
4. Connect the hookup wire, as shown in Figure D.4, to terminals 31 and 32. The hook up wire connects to the multimeter. Set the meter for DC volts. Make sure the screws are tight.
5. Reinsert chassis into the case, secure the front panel screws, and apply power. The 2nd display should read CALIBRATE while the 3rd display will read ANLG. IN. **Allow the station and meter to warm up for at least 45 minutes before proceeding.**

NOTE:

In the United States, the standard negative thermocouple lead is red.

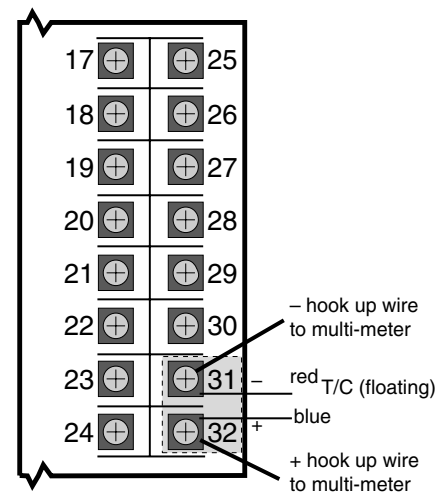

Figure D.4
Thermocouple & Cold Junction Calibration Wiring

NOTE:

Do not stand the station on its front or back ends; this will disrupt accurate temperature readings.

6. Press the **ACK** key for the first step in the **ANLG. IN** menu. The 2nd display will read CAL. VREF, while the 3rd display will read a value close to 5.0000. Refer to the flowchart in Figure D.1 for guidance.
7. Your meter should read a value between 4.9750 and 5.0250. Press **▲** and **▼** keys on the station until the 3rd display on the station matches your meter's reading. Note that the **FAST** key is active should you decide to use it to move more quickly.
8. Press **MENU**. The 2nd display reads CAL. 120mV and the 3rd display will now read a value close to 120mV. Repeat step 7.
9. Press **MENU** again and repeat this procedure for the remaining voltages (90mV, 60mV, 30mV and 0mV). Each time, you should match the displays of the station and your meter.
10. Upon completing the entire cycle, press **ACK**. The 2nd display reads CALIBRATE while the 3rd display will read COLD JUNC.
11. Power down, then up again. Wait at least 5 minutes before continuing.
12. Press **MENU** once. The 2nd display will read CALIBRATE while the 3rd display will read COLD JUNC. Press **ACK**.
13. Disconnect the test clips from the hook up wires on terminals 31 and 32. Connect T/C wires to the thermocouple calibrator instrument.
14. Set the thermocouple calibrator instrument to Output -150° C for T-Type. Allow the calibrator to stabilize for a few minutes.
15. Press **ACK** to initiate calibration of the cold junction.
16. If you will be calibrating milliamp output, move on to Milliamp Output Calibration, Step 5. Otherwise, power down and place the jumpers in their correct operating positions (as specified in Chapter 4).
17. **IMPORTANT!**

You must press ACK at the end of any calibration procedure to return to the calibration menu **before powering down**.

Milliamp Output Calibration

If your station uses milliamp outputs, then it is usually not necessary to calibrate them. If you are using milliamp output for accurate retransmission of data, you should calibrate each output whenever an analog module is installed. Once a year, recalibrate to maintain optimal performance.

Equipment:

- Precision 5-1/2 or 6-1/2 digit multimeter, such as a *Fluke 8842[®]* or *Hewlett Packard HP3478A[®]*
 - Two small pieces of wire for each milliamp output
 - Test leads with clip ends
 - #2 Phillips screwdriver
1. Disconnect power to the instrument.
 2. Remove chassis from case.
 3. Locate jumpers marked **PV 1** and **2nd** near the edge connector of the Microcontroller Board (refer to Figure D.2). Relocate both jumper connectors so that one is positioned on the pins marked **V** of the **2nd** jumper and the other on the pins marked **TC▲** of the **2nd** jumper.

4. ATTENTION:

The 532 local output should be calibrated at terminals 5 (OUT2-) and terminals 6 (OUT2+). **The bypass circuitry PC board does not have to be removed to perform the calibration.**

5. Connect the small pieces of wire to the terminals assigned to the milliamp output(s) you are calibrating. Figure D.5 shows the hook up wires applied to OUT3 positive and OUT3 negative. Hook up wires need to be applied to all terminals that have corresponding milliamp output modules in their output sockets. Attach the test leads from the multimeter to the wires, and then plug the test leads into the meter. Set the meter for DC milliamps.
 6. Reinsert chassis into the case and apply power. The 2nd display should read CALIBRATE while the 3rd display reads ANLG. IN. Press **MENU** twice to get to the **ANLG. OUT** menu. Use the flowchart in Figure D.1 as a guide to this procedure.
 7. Press **ACK**. The 2nd display will read OUTPUT X (where X is the output number 1, 2, 3 or 4 with a milliamp output module. Press **MENU** until the output you wish to calibrate is displayed. The flowchart in Figure D.7 illustrates how to move through the selection for each output module that needs to be calibrated.
 8. The 3rd display should read 4 mA. Your meter should read a value close to 4.00 mA. Wait one minute. Then press ▲ and ▼ key on the station until the meter's display reads 4.00 mA. You may press **FAST** with ▲ and ▼ key to change the value at a faster rate.
 9. Press **MENU**. The 3rd display should read 20 mA. Let this setting stabilize for one minute. Repeat the procedure from Step 7.
 10. To calibrate another analog output, move your wires and test leads to the new output terminals. Press **MENU** until you see 4 mA for the corresponding output in the 2nd display. Repeat Steps 7 through 9.
 11. To complete calibration, press **ACK**, and disconnect the power. Remove the station from its case, and place the jumpers in their correct operating positions (as specified in Chapter 4).
- 12. IMPORTANT!**
- You must press ACK** at the end of any calibration procedure to return to the calibration menu **before powering down**.

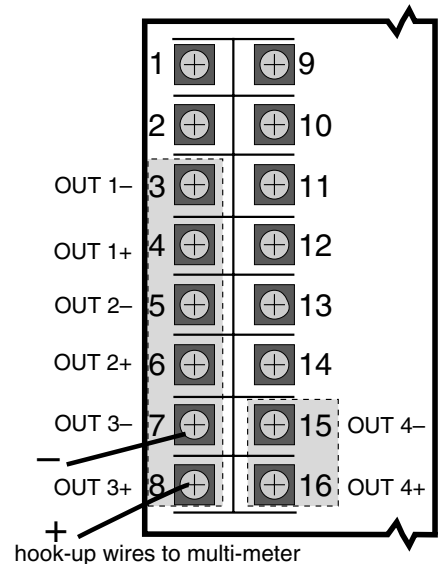

Figure D.5
Milliamp Calibration Wiring

NOTE:

If your multi-meter display does not register a response, check that the jumpers J1, J2 and J3 (on the Power Supply Board) are positioned as Normally Open (NO).

Reset Menu Data

Figure D.6 shows the flowchart for access to this function, that resets all parameter values back to their factory defaults (except for calibration information). Once inside the **Reset Menu Data** "menu":

1. Press **MENU** until the display shows RESET MENU DATA.
2. Press the **ACK**.

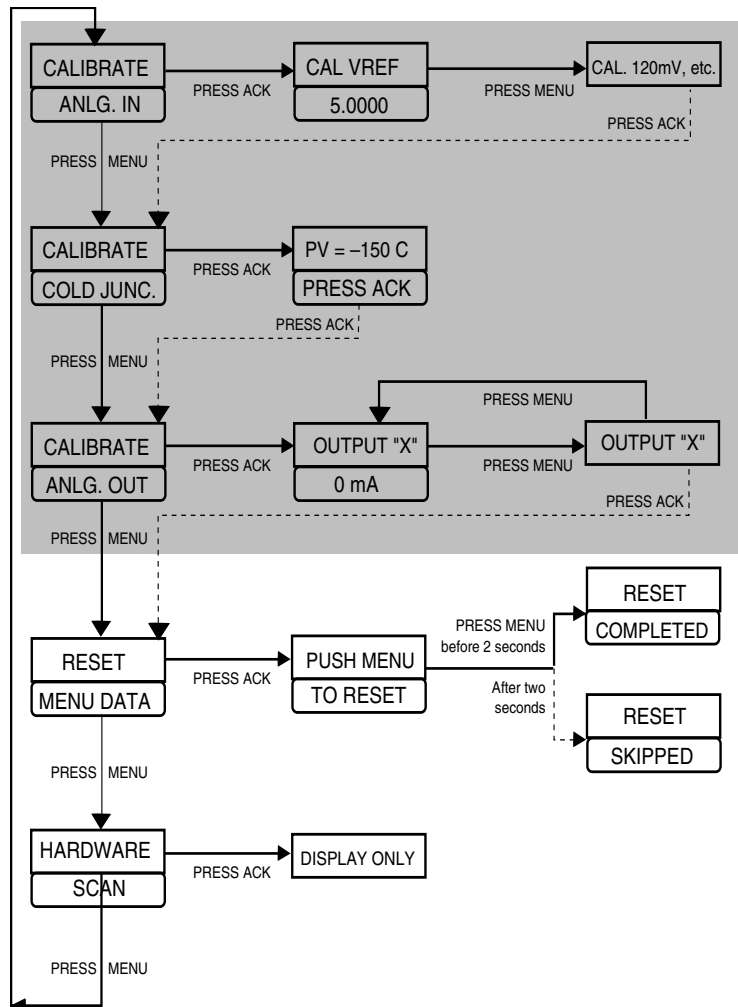

Figure D.6
Flowchart for Access to Reset and
Hardware Scan Menus

3. The display will prompt you to press **MENU** to reset the menu data. You have two seconds to press **MENU** to accomplish the reset. If successful, **RESET COMPLETED** will appear in the display.
4. If you failed to press **MENU** in time, **RESET SKIPPED** will appear.
5. To try again, press **ACK**, and then press **MENU** within two seconds.

Hardware Scan

This procedure identifies the internal parts of the station. Should you need to determine the hardware inside your station, press **ACK** to enter this read-only menu (see Figure D.6 for the flowchart). The station will display the types of output hardware and installed options. Press **MENU** to return to the beginning of the Calibrate menu cycle.

The information displayed should match the information on the product label on top of the controller. You can compare this information to the Order Code in Chapter 1. However, any hardware modifications will render the order code on the product label invalid.

APPENDIX E

SPECIFICATIONS

ACCURACY

	TYPICAL	MAXIMUM
LINEAR		
(Voltage)	± 0.025% full scale	± 0.100% full scale
(Current)	± 0.050% full scale	± 0.150% full scale
RTD		
1°	± 0.050% of span	± 0.150% of span
0.1°	± 0.095% of span	± 0.225% of span
THERMOCOUPLE		
J, K, N, E (> 0°C)	± 0.060% of span	± 0.150% of span
J, K, N, E (< 0°C)	± 0.150% of span	± 0.375% of span
T (> 0°C)	± 0.100% of span	± 0.250% of span
T (< 0°C)	± 0.250% of span	± 0.625% of span
R, S (> 500°C)	± 0.150% of span	± 0.375% of span
R, S (< 500°C)	± 0.375% of span	± 0.925% of span
B (> 500°C)	± 0.150% of span	± 0.375% of span
B (< 500°C)	± 0.500% of span	± 1.000% of span
W, W5 & Platinel II	± 0.125% of span	± 0.325% of span

Display accuracy is ± 1 digit. These accuracy specifications are at reference conditions (25°C) and only apply for NIST ranges. Detailed accuracy information is available upon request.

ISOLATION

Inputs and outputs are grouped into the following blocks:

- Block 1** — process variable indication
- Block 2** — outputs 1, 2, 3 and 4
- Block 3** — communications, set of five digital inputs
- Block 4** — setpoint and indicator

Each block is electrically isolated from the other blocks to withstand a HIPOT potential of 500Vac for 1 minute or 600Vac for 1 second, with the exception of blocks 1 and 4, which are not isolated, but is capable to withstand a potential of 50 volts peak for 1 minute between each other. Inputs and outputs are not isolated from other inputs and outputs within the same block.

PROCESS VARIABLE INDICATOR INPUTS

Universal input type. Any input type may be selected in the field. Selection of input type (thermocouple, RTD, voltage or current) via jumper. Selection of particular sensor or range is via front panel.

THERMOCOUPLES	RANGE °F	RANGE °C
B	104 to 3301	40 to 1816
E	-454 to 1832	-270 to 1000
J	-346 to 1832	-210 to 1000
K	-418 to 2500	-250 to 1371
N	-328 to 2372	-200 to 1300
R	32 to 3182	0 to 1750
S	32 to 3182	0 to 1750
T	-328 to 752	-200 to 400
W	32 to 4172	0 to 2300

THERMOCOUPLES	RANGE °F	RANGE °C
W5	32 to 4172	0 to 2300
Platinel II	-148 to 2550	-100 to 1399
RTD'S	RANGE °F	RANGE °C
100ohm Pt. (DIN)	-328 to 1562	-200 to 850
	-328.0 to 545.0	-200.0 to 285.0
100ohm Pt. (JIS)	-328 to 1202	-200 to 650
	-328.0 to 545.0	-200.0 to 285.0
100ohm Pt. (SAMA)	-328 to 1202	-200 to 650
	-328.0 to 545.0	-200.0 to 285.0

TRANSMITTER	SIGNAL INPUT RANGE
Milliamps DC	4 to 20 0 to 20
Voltage DC	1 to 5 0 to 5
Millivolts DC	0 to 10 0 to 30 0 to 60 0 to 100 -25 to 25

LINEARIZATION

Thermocouple and RTD inputs are automatically linearized. Transmitter inputs may be linearized with a square root function or user-defineable 15-point straight line linearization function.

INPUT IMPEDANCE

Current Input: 250ohm **Thermocouples:** 10 Mohm
Voltage Input: 1 Mohm **RTDs:** 10 Mohm

UPDATE RATE

Input is sampled and output updated 5 times per second. Display is updated 5 times per second. Passage of the HOST signal through the 532 is continuous.

INPUT FILTER

Single pole lowpass digital filter with selectable time constant from 0 to 120 seconds.

CALIBRATION

The station comes fully calibrated from the factory and continuously calibrates itself for component aging due to temperature and time, except for reference voltage. Field calibration can be performed easily with a precision multimeter and thermocouple simulator. Process variable offset and gain factors are provided to correct for sensor errors.

OUTPUT MODULES

One analog output (CV), 4-20mA into a load up to 1000ohms. Also available is solid state relay, DC logic, or an additional mechanical relay module that can be tied to an alarm.

Specifications

CONTROL OUTPUTS

Manually adjusted 4–20mA into a load up to 1000ohms.

ALARMS

The 532 has two powerful software alarms. It provides a LOCAL alarm that indicates when the the unit is in LOCAL mode. When tied to an available output, the HOST device can be flagged as to the change in status. If the PV indicator option is used, a PV High, PV Low and Rate alarm are available. If the SP indication option is also chosen, a SP Band and SP Deviation alarm are also available. A 9-character custom alarm message is available for each alarm.

DIGITAL INPUTS

A set of three external dry contacts or open collector driven transistor inputs are available. Each can be configured to perform one of the following functions:

- Select LOCAL control with LAST-OUT or 1 of 2 preset values
- Acknowledge alarms
- Addressable through serial communications only
- ▲/▼ Key Emulation
- Output Lock

SERIAL COMMUNICATIONS

Isolated serial communications is available using an RS-485 interface. Baud rates of up to 19,200 are selectable. The protocol supports CRC data checking. Output 1 can act as “host controller,” I/O independent of the controllers functions. May be installed in the field.

DIGITAL DISPLAYS

Displayed information depends upon chosen options.

Upper display: five-digit, seven-segment. If the PV option is chosen, displays PV. Normally displays CV in 0.1% increments. Height is 15mm (0.6 in.).

2nd display: nine-character, 14-segment alphanumeric. If 1st display indicates PV, 2nd indicates SP or valve position (VP) (transmitted from host), or CV. If the SP option is chosen, display will automatically alternate between SP and CV every 2 seconds. During set-up, displays configuration information. Height is 6mm (0.25 in.).

3rd display: nine-character, 14-segment alphanumeric. When no alarm messages are queued, indicates a user selectable “station” name. During set-up, displays configuration information. Height is 6mm (0.25 in.).

All displays are vacuum fluorescent. Color is blue-green.

STATUS INDICATORS

ALM 1 icon illuminated: alarm status

HOST key illuminated: CV signal from HOST is present

LOCAL key illuminated: 532 is in LOCAL mode

ACK key illuminated: alarm is acknowledged

MENU key illuminated: 532 is in configuration mode

DIMENSIONS

Meets 1/4 DIN designation as specified in DIN standard number 43 700. See diagram for details.

MOUNTING

Panel-mounted. See diagram for details.

WIRING CONNECTIONS

29 screw terminals in the rear of the instrument.

POWER CONSUMPTION

15VA at 120Vac, 60Hz (typical).

WEIGHT

Approximately 1 kg (2.2 lbs.).

AMBIENT TEMPERATURE

Operative Limits: 0 to 50°C (32 to 122°F).

Storage Limits: –40 to 70°C (–40 to 158°F).

RELATIVE HUMIDITY

10 to 90%, non-condensing.

POWER INPUT

Universal power supply: 90 to 250Vac, 48 to 62Hz.

NOISE IMMUNITY

Common mode rejection (process input): >120 dB.

Normal mode rejection (process input): >80 dB.

AC line is double filtered and transient protected. Internal snubbers are provided for each relay output.

CONSTRUCTION

Case: extruded, non-perforated black anodized aluminum with ABS plastic sleeve.

Bezel: black plastic ABS.

Chassis assembly: plug-in type.

Keys: silicone rubber with diffusion printed graphics.

NEMA rating: front panel conforms to NEMA 4X when instrument is properly installed.

AGENCY APPROVALS



LISTED
Process Control Equipment
4N66



Heavy
Industrial
(Available as an option)

MEMORY RETENTION

Lithium battery maintains all programming for approximately ten years.

SECURITY

There are two levels of access: restricted and full. A configurable code is used to enter the full access level. Functions not available in the restricted level are configurable.

RETURN PROCEDURES

To return equipment to Moore Industries for repair, follow these four steps:

1. Call Moore Industries and request a Returned Material Authorization (RMA) number.

Warranty Repair –

If you are unsure if your unit is still under warranty, we can use the unit's serial number to verify the warranty status for you over the phone. Be sure to include the RMA number on all documentation.

Non-Warranty Repair –

If your unit is out of warranty, be prepared to give us a Purchase Order number when you call. In most cases, we will be able to quote you the repair costs at that time. The repair price you are quoted will be a "Not To Exceed" price, which means that the actual repair costs may be less than the quote. Be sure to include the RMA number on all documentation.

2. Provide us with the following documentation:
 - a) A note listing the symptoms that indicate the unit needs repair
 - b) Complete shipping information for return of the equipment after repair
 - c) The name and phone number of the person to contact if questions arise at the factory
3. Use sufficient packing material and carefully pack the equipment in a sturdy shipping container.
4. Ship the equipment to the Moore Industries location nearest you.

The returned equipment will be inspected and tested at the factory. A Moore Industries representative will contact the person designated on your documentation if more information is needed. The repaired equipment, or its replacement, will be returned to you in accordance with the shipping instructions furnished in your documentation.

WARRANTY DISCLAIMER

THE COMPANY MAKES NO EXPRESS, IMPLIED OR STATUTORY WARRANTIES (INCLUDING ANY WARRANTY OF MERCHANTABILITY OR OF FITNESS FOR A PARTICULAR PURPOSE) WITH RESPECT TO ANY GOODS OR SERVICES SOLD BY THE COMPANY. THE COMPANY DISCLAIMS ALL WARRANTIES ARISING FROM ANY COURSE OF DEALING OR TRADE USAGE, AND ANY BUYER OF GOODS OR SERVICES FROM THE COMPANY ACKNOWLEDGES THAT THERE ARE NO WARRANTIES IMPLIED BY CUSTOM OR USAGE IN THE TRADE OF THE BUYER AND OF THE COMPANY, AND THAT ANY PRIOR DEALINGS OF THE BUYER WITH THE COMPANY DO NOT IMPLY THAT THE COMPANY WARRANTS THE GOODS OR SERVICES IN ANY WAY.

ANY BUYER OF GOODS OR SERVICES FROM THE COMPANY AGREES WITH THE COMPANY THAT THE SOLE AND EXCLUSIVE REMEDIES FOR BREACH OF ANY WARRANTY CONCERNING THE GOODS OR SERVICES SHALL BE FOR THE COMPANY, AT ITS OPTION, TO REPAIR OR REPLACE THE GOODS OR SERVICES OR REFUND THE PURCHASE PRICE. THE COMPANY SHALL IN NO EVENT BE LIABLE FOR ANY CONSEQUENTIAL OR INCIDENTAL DAMAGES EVEN IF THE COMPANY FAILS IN ANY ATTEMPT TO REMEDY DEFECTS IN THE GOODS OR SERVICES. BUT IN SUCH CASE THE BUYER SHALL BE ENTITLED TO NO MORE THAN A REFUND OF ALL MONIES PAID TO THE COMPANY BY THE BUYER FOR PURCHASE OF THE GOODS OR SERVICES.

ANY CAUSE OF ACTION FOR BREACH OF ANY WARRANTY BY THE COMPANY SHALL BE BARRED UNLESS THE COMPANY RECEIVES FROM THE BUYER A WRITTEN NOTICE OF THE ALLEGED DEFECT OR BREACH WITHIN TEN DAYS FROM THE EARLIEST DATE ON WHICH THE BUYER COULD REASONABLY HAVE DISCOVERED THE ALLEGED DEFECT OR BREACH, AND NO ACTION FOR THE BREACH OF ANY WARRANTY SHALL BE COMMENCED BY THE BUYER ANY LATER THAN TWELVE MONTHS FROM THE EARLIEST DATE ON WHICH THE BUYER COULD REASONABLY HAVE DISCOVERED THE ALLEGED DEFECT OR BREACH.

RETURN POLICY

For a period of thirty-six (36) months from the date of shipment, and under normal conditions of use and service, Moore Industries ("The Company") will at its option replace, repair or refund the purchase price for any of its manufactured products found, upon return to the Company (transportation charges prepaid and otherwise in accordance with the return procedures established by The Company), to be defective in material or workmanship. This policy extends to the original Buyer only and not to Buyer's customers or the users of Buyer's products, unless Buyer is an engineering contractor in which case the policy shall extend to Buyer's immediate customer only. This policy shall not apply if the product has been subject to alteration, misuse, accident, neglect or improper application, installation, or operation. THE COMPANY SHALL IN NO EVENT BE LIABLE FOR ANY INCIDENTAL OR CONSEQUENTIAL DAMAGES.



WORLDWIDE • www.miinet.com

United States • info@miinet.com
Tel: (818) 894-7111 • FAX: (818) 891-2816

Australia • sales@mooreind.com.au
Tel: (02) 8536-7200 • FAX: (02) 9525-7296

Belgium • info@mooreind.be
Tel: 03/448.10.18 • FAX: 03/440.17.97

The Netherlands • sales@mooreind.nl
Tel: (0)344-617971 • FAX: (0)344-615920

China • sales@mooreind.sh.cn
Tel: 86-21-62491499 • FAX: 86-21-62490635

United Kingdom • sales@mooreind.com
Tel: 01293 514488 • FAX: 01293 536852

5 3 2



5 3 2

1/4 DIN BACKUP STATION
Addendum to the User's Manual

 **MOORE
INDUSTRIES**

The 532 controller has been upgraded with a new microprocessor, new case, and modifications to the front panel to improve its NEMA 4X capability. Insert this information where appropriate in your M532 V5 manual.

Cover

The 532 station body has been modified to a 1-piece design, with a new face plate (4 screws instead of 2 securing it to the body).



Chapter 1, Page 1, Figure 1.1
 also
 Chapter 2, Page 5, Figure 2.1
 Chapter 2, Page 11, Figure 2.3
 Chapter 4, Page 19, Figure 4.1

This drawing shows a basic detail of the new faceplate. Please refer to this drawing for any detail of the controller face.

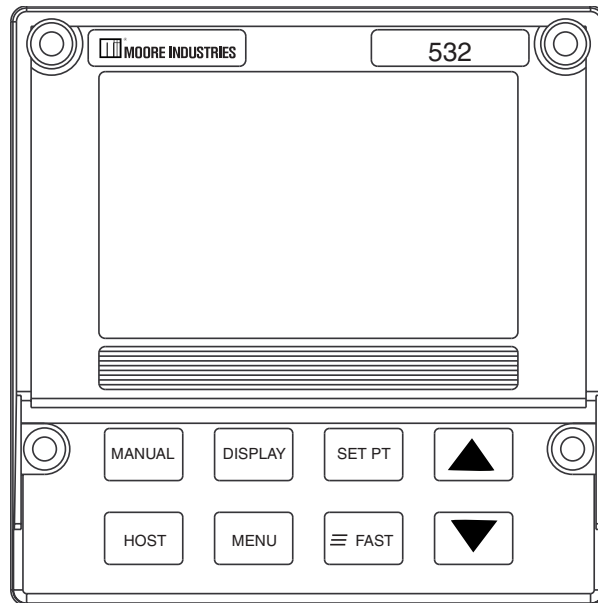

532 -

Output 1: Alarm

Order Code

- None..... 0
- Mechanical Relay..... 1
- Solid State Relay (triac) (1 amp)..... 3
- DC Logic (SSR drive)..... 4

Options

Enter "0" if not desired

- 24 VAC/24 VDC Operation..... F
- Set of 5 Digital Inputs D
- CE Certification..... H
- Set of 5 Digital Inputs w/ CE Certification J

Serial Communications

Enter "0" if not desired

- RS-485 Serial Communications..... S

Price includes universal input, remote setpoint, and 1mA output.

Chapter 3, Page 13, Figure 3.1

This drawing has been modified to incorporate the new controller body.

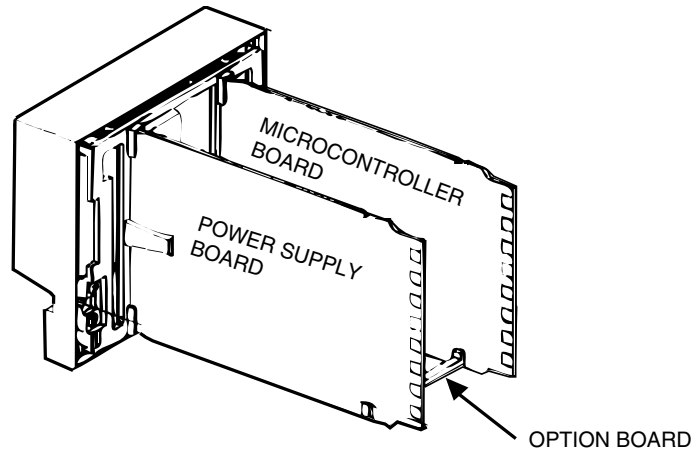

Chapter 3, Page 14, Figure 3.2

The Microcontroller Board has been modified.

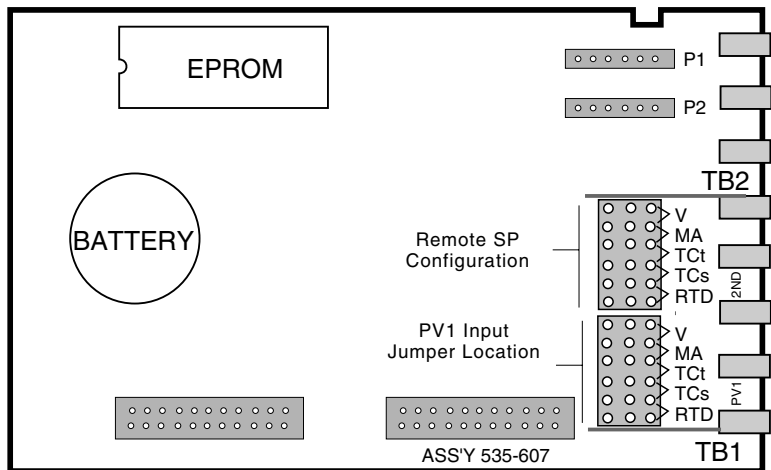

Chapter 4, Page 20, Figure 4.2

A mounting collar replaces the old mounting brackets.

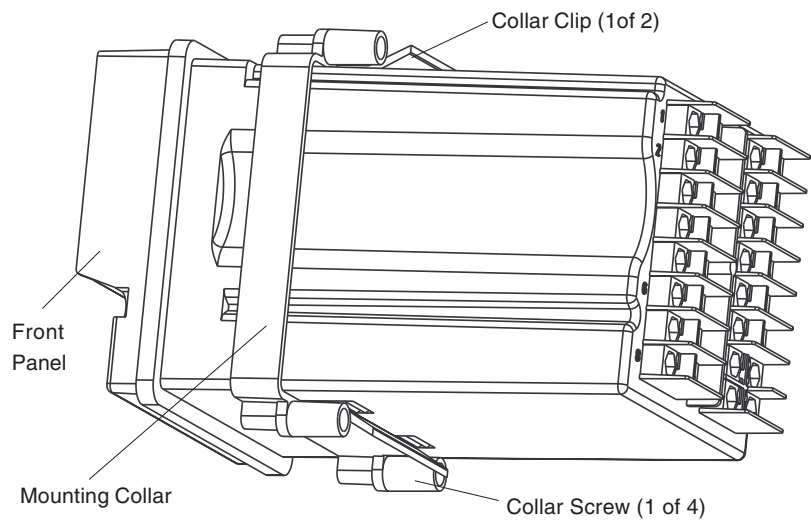

Chapter 4, Page 20

2c. Slide the mounting collar over the back of the case. The collar clip edges will lock with matching edges on the controller case.

2d. Insert the four mounting collar screws from the rear of the collar. Gradually tighten the screws to secure the controller against the panel.

Chapter 5, Pages 42-44

In the **ALARMS** Menu, four new types of alarms have been added (HIGH and LOW have been removed).

1. ALM. TYPE:1

(D) OFF

- LOCAL
- HIGH PV
- LOW PV
- RATE
- BAND
- DEVIATION
- HIGH CV
- LOW CV
- HI/LO CV
- HI/LO PV

Separate High and Low CV setpoints in one alarm

Separate High and Low PV setpoints in one alarm

2. ALARM SP:1

Specifies the alarm set point for alarm 1.

For RATE alarms:

(R) -9999 to 99999

(D) 0

For HIGH CV or LOW CV alarms:

(R) 0.0 to 100.0%

(D) 0.0%

For any other type (except HI/LO CV, HI/LO PV or HIGH/LOW)

(R) The PV range

(D) Dependent on LOW RANGE value

3. DEADBAND:1

Specifies the high alarm set point for HI/LO or HIGH/LOW alarm 1.

For HI/LO CV alarms:

(R) 0.0% to 100.0%

(D) 0.0%

For HI/LO PV or HIGH/LOW alarms:

(R) LOW RANGE to HI RANGE

(D) 0

4. RELAY:1

Specifies the high alarm set point for HI/LO or HIGH/LOW alarm 1.

For HI/LO CV alarms:

(R) 0.0% to 100.0%

(D) 0.0%

For HI/LO PV or HIGH/LOW alarms:

(R) LOW RANGE to HI RANGE

(D) 0

9. ALM. TYPE:2

(D) OFF

- LOCAL
- HIGH PV
- LOW PV
- RATE
- BAND
- DEVIATION
- HIGH CV
- LOW CV
- HI/LO CV
- HI/LO PV

Separate High and Low CV setpoints in one alarm

Separate High and Low PV setpoints in one alarm

10. ALARM SP:2

Specifies the alarm set point for alarm 2.

For RATE alarms:

(R) -9999 to 99999

(D) 0

For HIGH CV or LOW CV alarms:

(R) 0.0 to 100.0%

(D) 0.0%

For any other type (except HI/LO CV, HI/LO PV or HIGH/LOW)

(R) The PV range

(D) Dependent on LOW RANGE value

11. DEADBAND:2

Specifies the high alarm set point for HI/LO or HIGH/LOW alarm 2.

For HI/LO CV alarms:

(R) 0.0% to 100.0%

(D) 0.0%

For HI/LO PV or HIGH/LOW alarms:

(R) LOW RANGE to HI RANGE

(D) 0

12. RELAY:2

Specifies the high alarm set point for HI/LO or HIGH/LOW alarm 2.

For HI/LO CV alarms:

(R) 0.0% to 100.0%

(D) 0.0%

For HI/LO PV or HIGH/LOW alarms:

(R) LOW RANGE to HI RANGE

(D) 0

ALARMS

Parameter	Description	Value
1 ALM. TYPE:1	Type of alarm for alarm 1	
2 ALARMSP:1	Alarm setpoint alarm 1	
3 DEADBAND:1	Dead band for alarm 1	
4 RELAY:1	State of the relay for alarm 1	
5 LATCHING:1	Latching sequence for alarm 1	
6 ACK.:1	Whether alarm 1 may be acknowledged	
7 POWERUP:1	How alarm 1 will be treated upon power up	
8 MESSAGE:1	Nine character message associated with alarm 1	
9 ALM. TYPE:2	Type of alarm for alarm 2	
10 ALARMSP:2	Alarm setpoint alarm 2	
11 DEADBAND:2	Dead band for alarm 2	
12 RELAY:2	State of the relay for alarm 2	
13 LATCHING:2	Latching sequence for alarm 2	
14 ACK.:2	Whether alarm 2 may be acknowledged	
15 POWERUP:2	How alarm 2 will be treated upon power up	
16 MESSAGE:2	Nine character message associated with alarm 2	
17 RATE TIME	Time period over which a rate-of-change is determined	

Chapter 6, Page 56

Under Alarm Set Up, here are all the types of alarms

OFF

LOCAL

HIGH PV

Occurs when the process variable goes above the alarm setpoint

LOW PV

Occurs when the process variable goes below the alarm setpoint

BAND

DEVIATION

RATE

HIGH CV

Occurs when the control value goes above the alarm setpoint

LOW CV

Occurs when the control value goes below the alarm setpoint

HI/LO CV

Combination of High and Low alarms. Occurs when the control value exceeds the individually set high or low setpoint.

HI/LO PV

Combination of High and Low alarms. Occurs when the process variable exceeds the individually set high or low setpoint.

Chapter 6, Page 58

In conjunction with the new alarm types, under B. Set the Alarm Parameters, add the following parameters after ALARM SP.

5. DEADBAND:1 and DEADBAND:2

High alarm setpoint. For a HI/LO CV, HI/LO PV, or HIGH/LOW alarm, defines the high end setpoint at which an alarm occurs.

6. RELAY:1 and RELAY:2

Low alarm setpoint. For a HI/LO CV, HI/LO PV, or HIGH/LOW alarm, defines the low end setpoint at which an alarm occurs.

The Menu Flowchart has been modified accordingly:

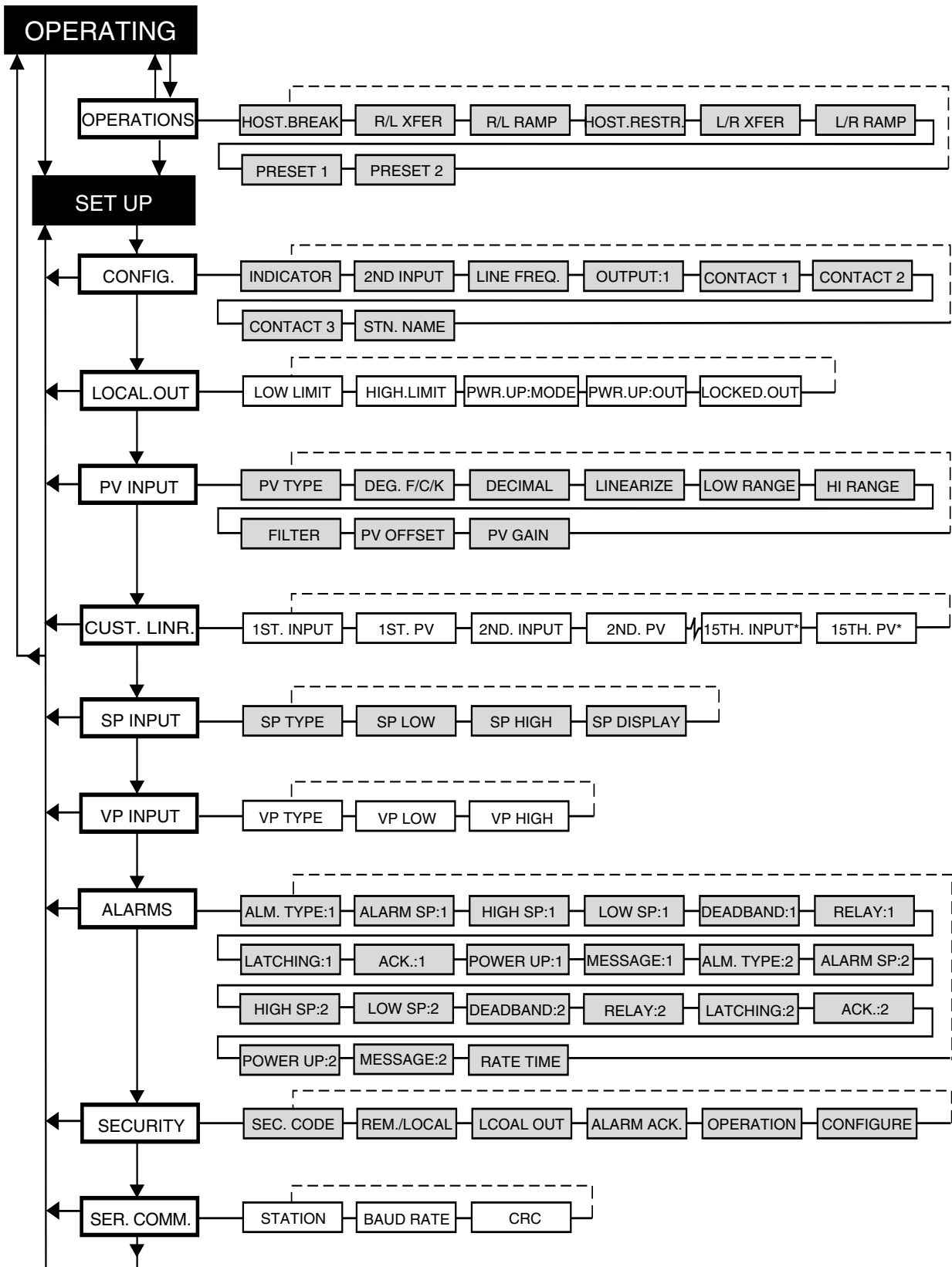

With the modifications to the case and addition of the mounting collar, the parts drawings have been modified. Also, note the new parts numbers.

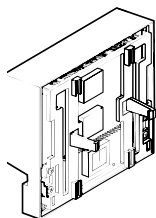

OPERATOR
INTERFACE
ASSEMBLY
shown with bezel
insert in place

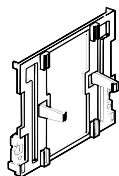

CIRCUIT
BOARD SUPPORT
(BEZEL INSERT)

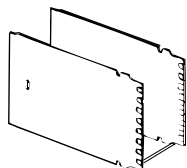

CIRCUIT BOARDS

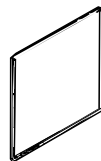

BEZEL
GASKET

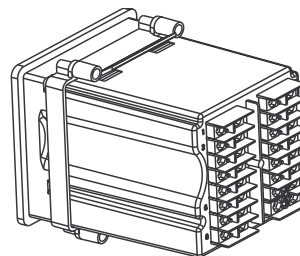

CONTROLLER BODY
shown with mounting
collar in place

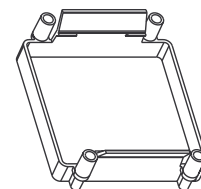

MOUNTING
COLLAR

ITEM	PART #	ITEM	PART #
Output Modules		Repair/Replacement Parts	
Mechanical Relay Module	535 600	532 Operator Interface Assembly	532 632
532 Analog (mA module)	532 600	Power Supply Circuit Board	535 730
Solid State Relay Module	535 602	532 Microcontroller Circuit Board	535 731
DC Logic (SSR Drive) Module	535 603	Option Circuit Board w/no Options	535 720
Loop Power Module	535 604	532 Option Circuit Board w/5 Digital Contacts	535 721
RS-485 Communications Module	535 705	532 EPROM	532 740
		Lithium Battery	093 044
		Jumper Kit: Set of All Jumper Connectors	535 660
		Gasket Kit: 1 Panel Gasket & 1 Bezel Gasket	535 662
		Mounting Kit: Mounting Collar & 4 screws	535 761
		Bezel Retention Screw Kit	535 663
		Module Retention Kit for Outputs 1-3 (Includes Retention Plate)	535 664
		Module Retention Kit for Output 4:	
		Set of 5 Tie Wraps	535 665
		Circuit Board Support (Bezel Insert)	535 075
		Engineering unit labels (1 sheet)	535 106
		532 Bypass board	532 100

	When does it occur?	What to do:
DEFAULTS	Whenever the memory is cleared and all parameters revert to factory default settings. This may be done by purposely clearing the memory or when the unit is powered up for the first time or if the software version is changed.	Changing any Set Up parameter will clear the message. If due to something other than the user purposely clearing the memory, call factory for assistance.
LOST CAL. or ERROR: BAD CAL. DATA	Indicates that the calibration data has been lost. Occurs when there is a total loss of memory.	Problem should never happen. Must correct the situation and recalibrate. Call factory for assistance.
ERROR: ROM CHECKSUM	On power up a problem with the EPROM is detected. Controller locks up until fixed.	Call factory for assistance.
OUT1 CONF	Upon power up, controller senses that the modules needed for control as determined by software configuration are not present.	Must power down and install correct module combination or must reconfigure the controller to match the current module combination.
LOSTCJC	The cold junction is sensed as lost.	Call factory for assistance.
ERROR: BAD EEPROM	During power up an EEPROM failure is detected. Controller locks up until fixed.	This is a fatal error and requires an EEPROM change. Call factory for assistance.
NEEDS CAL.	When the controller is powered up with default calibration data (input and output accuracy specifications may be met).	Enter calibration menu and recalibrate the controller. Call factory for assistance.
ERROR: BAD MODEL NUM.	During power up, a discrepancy was found between the EEPROM's and controller's model numbers. Controller locks up until fixed.	This is a fatal error and requires an EPROM or EEPROM change. Call factory for assistance.

The following pages replace Appendix D of the 532 manual.

APPENDIX D

CALIBRATION

- To maintain optimum performance, once a year calibrate the analog input, the cold junction and milliamp output (when used). To achieve published accuracy specifications, follow directions carefully and use calibrated instruments of like quality to those suggested.
- If the controller is moved into an alternate case, or the hardware configuration is changed, and the thermocouple input is needed, recalibrate the cold junction for maximum accuracy. Failure to do so may result in small junction temperature (0.6°C/1.1°F).

Access the parts of the calibration menu as shown in *Figure D.1*.

Important:

The 532 comes from the factory with one milliamp output module installed in position (output) 2 and relays in positions (outputs) 3 and 4. **These must not be modified.** You may install a mechanical relay, solid state relay or DC logic module in position (output) 1 for alarm functions.

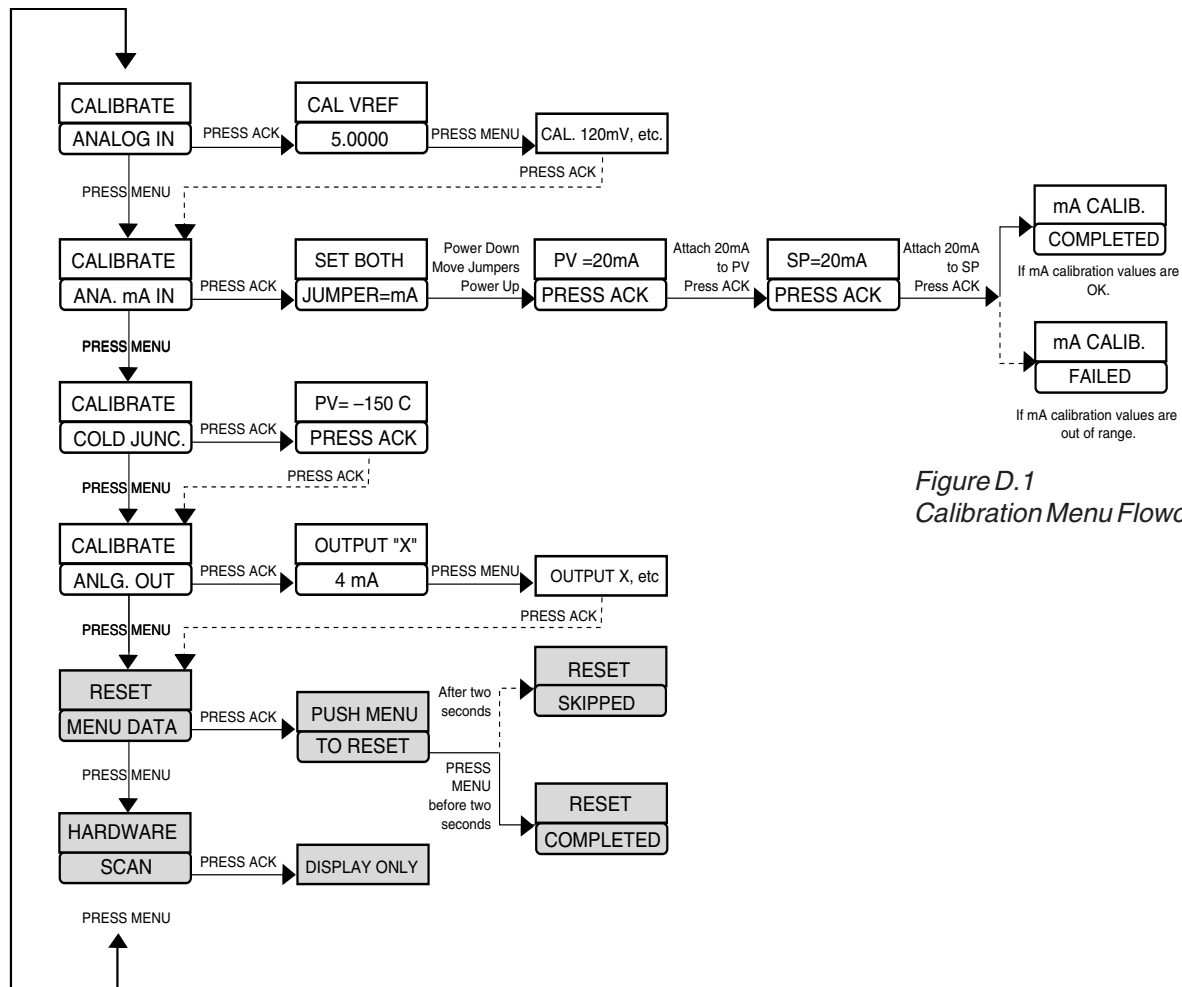
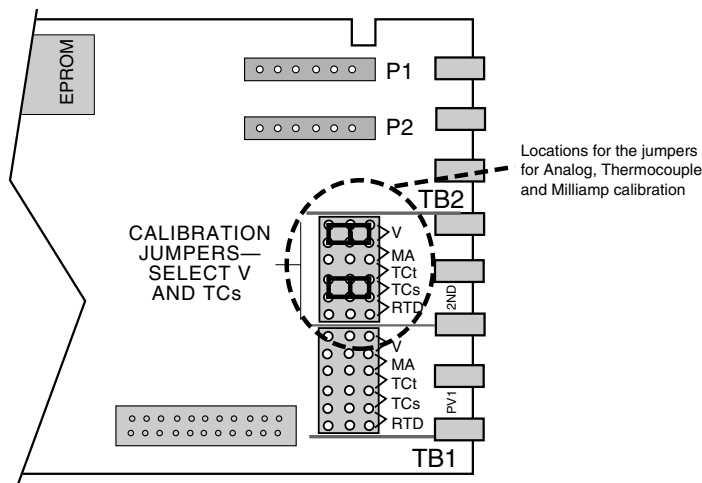

Figure D.1
Calibration Menu Flowchart

Figure D.2
Jumper Locations on the
Microcontroller Circuit Board



PREPARATION for all Input Calibration

Equipment for analog input calibration:

- Precision 5-1/2 or 6-1/2 digit multimeter, e.g., Fluke 8842® or HP3478A® (a 4-1/2 digit meter will sacrifice accuracy)
- Four small pieces of wire
- Test leads with clips
- #2 Phillips screwdriver

Additional equipment for thermocouple input:

- Precision thermocouple calibrator, e.g., Micromite II® by Thermo Electric Instruments
- Special limits grade, Type T thermocouple wire

1. Disconnect power to the instrument.
2. Remove chassis from case.
3. On the Microcontroller Circuit Board, locate jumper locations marked PV1 and 2nd near the edge connector. Reposition both jumper connectors in the 2nd location onto pins for **V** and **TC▲** as shown in *Figure D.2*.

4. Connect hook up wires between terminals 31 and 32 as shown in *Figure D.3*, and the multimeter.

Set the meter for **DC volts**.

5. Reinsert chassis into the case and apply power.
The 2nd and 3rd display should read CALIBRATE ANALOG IN.
6. Allow the controller to warm up for at least 30 minutes.
7. Press the **ACK** key to get to the first step/parameter.
The 2nd display should show CAL. VREF; the 3rd display should show a value close to 5.0000.
8. The multimeter should read a value in the range 4.9750 - 5.0250.
Use the **▲** and **▼** (and **FAST**) keys on the controller until the display on the controller matches the meter reading.
9. Press **MENU** key.
The 2nd display should show CAL. 120mV.
The 3rd display should show a value close to 120.000.

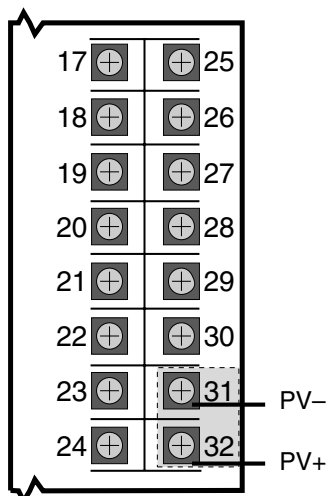

Figure D.3
Input Calibration Wiring

WARNING!

ELECTRIC SHOCK HAZARD!

Terminals 1 and 2 carry live power. Do not touch these terminals when AC power is on.

10. Press **MENU** three more times. Each time, match the displays of the controller and the multimeter. Press **ACK** when done.
The 2nd display should show CALIBRATE; the 3rd display should show ANA. mA IN.
11. Turn off power to the unit.
12. For **thermocouple input**, proceed to Thermocouple Cold Junction Calibration.
12. For **analog milliamp input**, proceed to Analog mA Input Calibration.
13. For **milliamp output**, proceed to Milliamp Output Calibration. Let the controller warm up for 10 minutes, then skip to step 5.
14. If **calibration is complete**, place all the jumpers back in their original positions (as specified in Chapter 3).

THERMOCOUPLE & COLD JUNCTION CALIBRATION

1. Connect the two pairs of T/C wire to terminals 28, 29, 31 and 32 as shown in *Figure D.4*. Make sure the T/C wires are floating (disconnect from the multimeter also), and are not touching each other.
2. Turn on power to the unit and let controller warm up for 30 minutes in the normal horizontal position: while the unit is warming up, the rear face of the controller should be vertical, not horizontal.
3. Press the **MENU** key until the display indicates CALIBRATE COLD JUNC.
4. Press the **ACK** key. The display should show PV = -150 C PRESS ACK.
5. Connect both pairs of T/C wires in parallel—do not daisy chain—to the Type T thermocouple calibrator. (Both pairs must be connected or the calibration will not be accurate.)
6. Set the thermocouple calibrator to an output value of -150° C for a Type T thermocouple and allow the calibrator to stabilize for a few minutes.
7. Press **ACK** to initiate calibration of the cold junction.
8. For Milliamp output calibration, proceed to the Milliamp Output Calibration Procedure. Let the controller warm up for 10 minutes, then skip to step 5.
9. If calibration is complete, power down, then place all the jumpers in their original positions (as specified in Chapter 3).

ANALOG mA INPUT CALIBRATION

1. Remove the thermocouple wires (if present) from terminals 28, 29, 31 and 32, and replace them with pieces of wire that will be connected to a 20 milliamp input current (see *Figure D.5*). Make sure terminal screws are securely tightened, but **do not** connect the wires yet (leave inputs floating).
2. Turn on power to the unit.
3. Press **MENU** until the display reads CALIBRATE ANA. mA IN, then press **ACK**.
If the display reads PV=20mA PRESS ACK, move ahead to step #8.
4. The controller will display SET BOTH JUMPER=mA.
5. Power down the controller and remove chassis from the case.
6. Remove both input jumper connectors from the pins in the 2nd position. Place one of the jumpers on the PV1 position **mA** pins, and place the other jumper on the 2nd position **mA** pins (see *Figure D.5A*)

Figure D.4
Thermocouple & Cold Junction Calibration Wiring

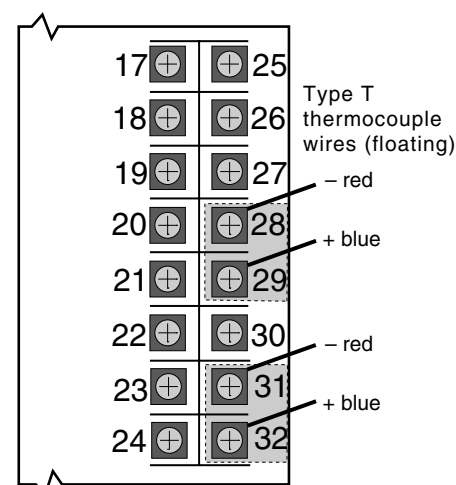

Figure D.5
Analog mA Input Wiring

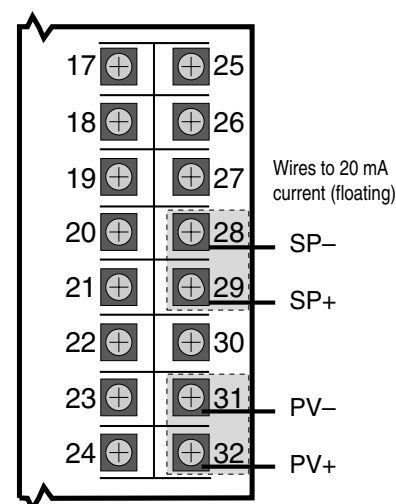
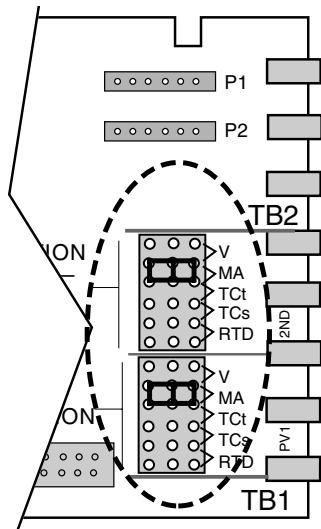

Figure D.5A
Analog mA Input Jumpers



7. Reinsert the chassis into the case and apply power. The controller should display PV=20mA PRESS ACK to indicate it is ready to calibrate the PV milliamp input.
8. Connect a precision 20mA input to only the PV terminal wires (31 is PV-, 32 is PV+). Make sure the terminal connections are fastened tightly and that a 20mA current is flowing through PV. **Do not** connect current to the SP terminal wires yet.
9. Let the controller warm up for at least 10 minutes (keep in normal horizontal position). Make sure the current is flowing, then press ACK to calibrate the PV input.
10. If the controller displays SP=20mA PRESS ACK, PV calibration was successful. Move on to step 12.
11. If the controller briefly displays mA CALIB. FAILED, PV calibration was not successful.
Check the 20mA connections, and return to step #3 to recalibrate the PV input.
12. Remove the 20mA input from the PV terminals, and attach it to the SP terminals (see Figure D.5).
Make sure the terminal connections are fastened tightly and that a 20mA current is flowing through SP.
13. Let the controller warm up for an additional 5 minutes (keep in the normal horizontal position). Make sure the current is flowing, then press **ACK** to calibrate the SP input.
14. If the controller displays mA CALIB. COMPLETED, SP calibration was successful and the analog milliamp calibration procedure has been completed.
Power down, then place the jumpers back into their original positions (see Chapter 3).
15. If the controller displays mA CALIB. FAILED, SP calibration was not successful. Check the 20mA connections, and return to step #3 to recalibrate the PV and SP inputs.

MILLIAMP OUTPUT CALIBRATION

If the station uses milliamp outputs, it is usually not necessary to calibrate them. If the milliamp output are being used for accurate retransmission of data, it is recommended that each output with an analog module be calibrated annually to maintain optimal performance.

Equipment needed:

- Precision 5-1/2 digit multimeter, e.g., Fluke 8842® or HP3478A® (4-1/2 digit meters sacrifice accuracy)
 - Two small pieces of wire for every milliamp output
 - Test leads with banana clips
 - #2 Phillips screwdriver
1. Disconnect power to the instrument.
 2. Remove chassis from case.
 3. On the Microcontroller Circuit Board locate jumper locations marked PV1 and 2nd near the edge connector. Reposition both jumper connectors in the 2nd location onto pins for **V** and **TC▲**, as shown in Figure D.2.

4. Reinsert chassis into the case and apply power.
5. Allow controller to warm up for at least 30 minutes.
The 2nd and 3rd displays should read CALIBRATE ANALOG. IN. (CALIBRATE Menu, ANALOG. IN section).
Press **MENU** three times to reach the CALIBRATE ANLG. OUT Menu.
6. Connect hook up wires to the terminals for the **532 local output (terminals 5 and 6)**. The PC circuitry board does not have to be removed to perform this calibration (see *Figure D.6*)
Attach the test leads from the multimeter to the wires, and then plug the test leads into the meter. Set the meter for DC milliamp.
7. Press **ACK**. The 2nd display will OUTPUT2.
8. The 3rd display should read 4 mA.
The multimeter should read a value close to 4.00.
9. Wait one minute. Use **▲** and **▼** (and **FAST**) on the controller to change the meter's display to exactly 4.00 mA.
10. Press **MENU**. The 3rd display should read 20 mA.
11. Let this setting stabilize for 5 minutes. Use **▲** and **▼** (and **FAST**) on the controller to change the meters display to exactly 20mA.
12. To complete calibration, press **ACK** key, disconnect the power and place the jumper connectors back into their original position (see Chapter 3).

Figure D.6
Milliamp Output Calibration Wiring

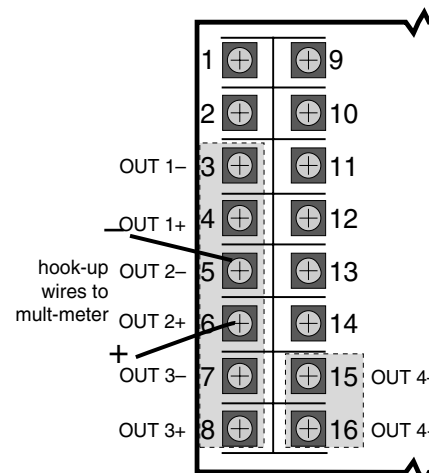

RESET MENU DATA

This function resets all parameter values back to their factory default values (except for calibration information). Refer to the flowchart in *Figure D.2*.

1. Disconnect power to the instrument.
2. Remove chassis from case.
3. On the Microcontroller Circuit Board, set jumpers at the 2nd PV location to **V** and **TC▲**.
4. Press **MENU** until the display shows RESET MENU DATA.
5. Press **ACK**.
6. Press **MENU** key within two seconds to reset the menu data.
If successful, RESET COMPLETED will appear in the display.
If failed, RESET SKIPPED will appear instead.
7. To try again, press **ACK** key, and then press **MENU** key within two seconds.
8. When complete, power down and return jumpers to their original positions.

HARDWARE SCAN

Use this read-only feature to identify the output hardware and installed options of the controller.

1. Set the jumpers to **V** and **TC▲** on the Microcontroller Circuit Board (see *Figure D.3*).
2. Power up the controller
3. Press **MENU** until HARDWARE SCAN is displayed.
4. Press **ACK** to initiate the hardware display.
5. When complete, power down and return jumpers to their original positions.

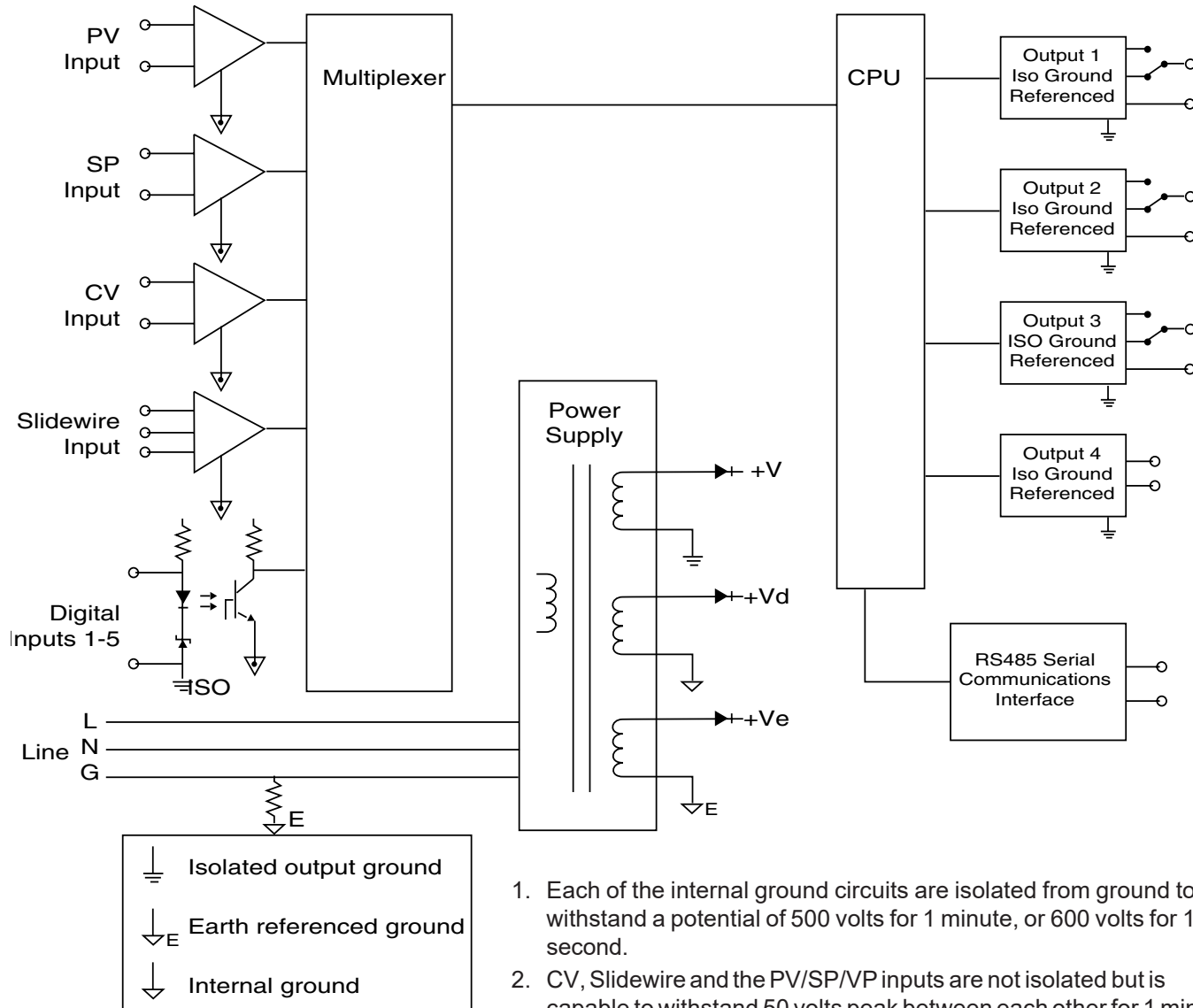

1. Each of the internal ground circuits are isolated from ground to withstand a potential of 500 volts for 1 minute, or 600 volts for 1 second.
2. CV, Slidewire and the PV/SP/VP inputs are not isolated but is capable to withstand 50 volts peak between each other for 1 minute.
3. Milliamp, Loop Power and SSR Drive modules in output positions 1, 2, 3 and 4 are not isolated from each other.
4. Inputs are not isolated from the analog output due to the failsafe pass through circuit.

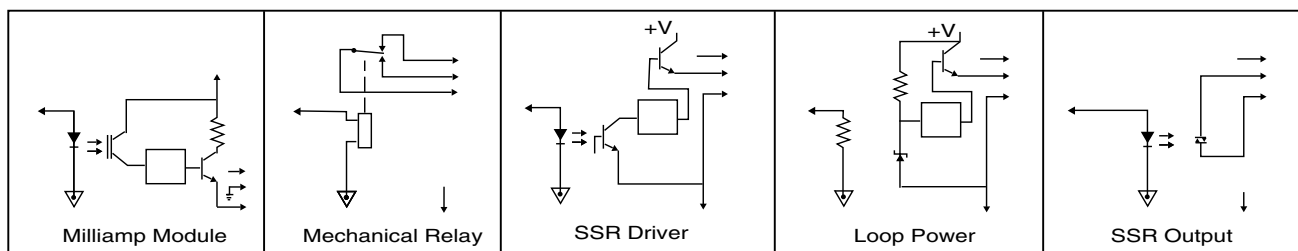

RETURN PROCEDURES

To return equipment to Moore Industries for repair, follow these four steps:

1. Call Moore Industries and request a Returned Material Authorization (RMA) number.

Warranty Repair –

If you are unsure if your unit is still under warranty, we can use the unit's serial number to verify the warranty status for you over the phone. Be sure to include the RMA number on all documentation.

Non-Warranty Repair –

If your unit is out of warranty, be prepared to give us a Purchase Order number when you call. In most cases, we will be able to quote you the repair costs at that time. The repair price you are quoted will be a "Not To Exceed" price, which means that the actual repair costs may be less than the quote. Be sure to include the RMA number on all documentation.

2. Provide us with the following documentation:
 - a) A note listing the symptoms that indicate the unit needs repair
 - b) Complete shipping information for return of the equipment after repair
 - c) The name and phone number of the person to contact if questions arise at the factory
3. Use sufficient packing material and carefully pack the equipment in a sturdy shipping container.
4. Ship the equipment to the Moore Industries location nearest you.

The returned equipment will be inspected and tested at the factory. A Moore Industries representative will contact the person designated on your documentation if more information is needed. The repaired equipment, or its replacement, will be returned to you in accordance with the shipping instructions furnished in your documentation.

WARRANTY DISCLAIMER

THE COMPANY MAKES NO EXPRESS, IMPLIED OR STATUTORY WARRANTIES (INCLUDING ANY WARRANTY OF MERCHANTABILITY OR OF FITNESS FOR A PARTICULAR PURPOSE) WITH RESPECT TO ANY GOODS OR SERVICES SOLD BY THE COMPANY. THE COMPANY DISCLAIMS ALL WARRANTIES ARISING FROM ANY COURSE OF DEALING OR TRADE USAGE, AND ANY BUYER OF GOODS OR SERVICES FROM THE COMPANY ACKNOWLEDGES THAT THERE ARE NO WARRANTIES IMPLIED BY CUSTOM OR USAGE IN THE TRADE OF THE BUYER AND OF THE COMPANY, AND THAT ANY PRIOR DEALINGS OF THE BUYER WITH THE COMPANY DO NOT IMPLY THAT THE COMPANY WARRANTS THE GOODS OR SERVICES IN ANY WAY.

ANY BUYER OF GOODS OR SERVICES FROM THE COMPANY AGREES WITH THE COMPANY THAT THE SOLE AND EXCLUSIVE REMEDIES FOR BREACH OF ANY WARRANTY CONCERNING THE GOODS OR SERVICES SHALL BE FOR THE COMPANY, AT ITS OPTION, TO REPAIR OR REPLACE THE GOODS OR SERVICES OR REFUND THE PURCHASE PRICE. THE COMPANY SHALL IN NO EVENT BE LIABLE FOR ANY CONSEQUENTIAL OR INCIDENTAL DAMAGES EVEN IF THE COMPANY FAILS IN ANY ATTEMPT TO REMEDY DEFECTS IN THE GOODS OR SERVICES. BUT IN SUCH CASE THE BUYER SHALL BE ENTITLED TO NO MORE THAN A REFUND OF ALL MONIES PAID TO THE COMPANY BY THE BUYER FOR PURCHASE OF THE GOODS OR SERVICES.

ANY CAUSE OF ACTION FOR BREACH OF ANY WARRANTY BY THE COMPANY SHALL BE BARRED UNLESS THE COMPANY RECEIVES FROM THE BUYER A WRITTEN NOTICE OF THE ALLEGED DEFECT OR BREACH WITHIN TEN DAYS FROM THE EARLIEST DATE ON WHICH THE BUYER COULD REASONABLY HAVE DISCOVERED THE ALLEGED DEFECT OR BREACH, AND NO ACTION FOR THE BREACH OF ANY WARRANTY SHALL BE COMMENCED BY THE BUYER ANY LATER THAN TWELVE MONTHS FROM THE EARLIEST DATE ON WHICH THE BUYER COULD REASONABLY HAVE DISCOVERED THE ALLEGED DEFECT OR BREACH.

RETURN POLICY

For a period of thirty-six (36) months from the date of shipment, and under normal conditions of use and service, Moore Industries ("The Company") will at its option replace, repair or refund the purchase price for any of its manufactured products found, upon return to the Company (transportation charges prepaid and otherwise in accordance with the return procedures established by The Company), to be defective in material or workmanship. This policy extends to the original Buyer only and not to Buyer's customers or the users of Buyer's products, unless Buyer is an engineering contractor in which case the policy shall extend to Buyer's immediate customer only. This policy shall not apply if the product has been subject to alteration, misuse, accident, neglect or improper application, installation, or operation. THE COMPANY SHALL IN NO EVENT BE LIABLE FOR ANY INCIDENTAL OR CONSEQUENTIAL DAMAGES.



WORLDWIDE • www.miinet.com

United States • info@miinet.com
Tel: (818) 894-7111 • FAX: (818) 891-2816

Australia • sales@mooreind.com.au
Tel: (02) 8536-7200 • FAX: (02) 9525-7296

Belgium • info@mooreind.be
Tel: 03/448.10.18 • FAX: 03/440.17.97

The Netherlands • sales@mooreind.nl
Tel: (0)344-617971 • FAX: (0)344-615920

China • sales@mooreind.sh.cn
Tel: 86-21-62491499 • FAX: 86-21-62490635

United Kingdom • sales@mooreind.com
Tel: 01293 514488 • FAX: 01293 536852

500 SERIES

Process Controllers

Form M500 V7

5 0 0

Hardware Installation and Modification Manual

***for Electronic Products
Series 531, 532,
535, 545, 555
Model 2***



Installation

INTRODUCTION

This technical brochure provides hardware installation and modification instructions for our controllers: **Series 531, 532, 535, 545, and 555. Use these instructions with the following kits:**

Display Assembly Kits

531-632	531 Display Assembly Kit
532-632	532 Display Assembly Kit
535-632	535 Display Assembly Kit
545-634	545 Display Assembly Kit
555-632	555 Display Assembly Kit

Output and Communications Module Kits

532-600	531, 532 Analog Module Kit
535-600*	Mechanical Relay Module Kit
535-601*	Milliamp Module Kit
535-602*	SSR Module Kit
535-603*	SSR Drive Module Kit
535-604*	Loop Power Module Kit
535-705*	RS-485 Communications Module Kit

Power Supply Kit

535-730*	90 to 250VAC Power Supply Kit
535-732	24VAC/VDC Power Supply Kit

Mounting Kit

535-761*	Mounting Kit
----------	--------------

Miscellaneous Kits

532-100	531, 532 Bypass Board Kit
535-188*	Rear Terminal Upgrade Kit
535-660	531, 532, 535, 545, 555 Jumper Kit
535-662*	Gasket Kit (1 Panel Gasket, 1 Bezel Gasket)
535-763*	Bezel Retention Screw Kit
535-664*	Module Retention Kit (Retention Plate and Tie Wrap)
535-665*	Module Retention Tie Wrap Kit
093-128*	Lithium Battery

EPROM Kits

531-740	531 EPROM Kit
532-740	532 EPROM Kit
535-741	535 EPROM Kit (RSP)
535-775	535 Profiler EPROM Kit (No RSP)
535-776	535 Profiler EPROM Kit (RSP)
535-740	535 EPROM Kit (No RSP)
545-740	545 EPROM Kit (No RSP)
545-741	545 EPROM Kit (RSP)
555-740	555 EPROM Kit

Microcontroller (MCU) Board Kits

535-731	MCU Board Kit
545-733	MCU Board Kit with CE Option

Option Board Kits

535-720	531, 532, 535, 545 Option Board Kit (No Options)
535-721	531, 532, 535, 545 Option Board Kit (Digital Inputs)
535-722	535, 545 Option Board Kit (Slidewire Feedback)
535-723	535, 545 Option Board Kit (Digital Inputs and Slidewire Feedback)
545-724	531, 532, 535, 545, 555 Option Board Kit (RSP)
545-725	531, 532, 535, 545, 555 Option Board Kit (Digital Inputs and RSP)
545-726	535, 545, 555 Option Board Kit (Slidewire Feedback and RSP)
545-727	535, 545, 555 Option Board Kit (Digital Inputs, Slidewire Feedback, and RSP)

* **Universal Kit (can be used with all 500 Series Controllers)**

HOW TO USE THIS MANUAL:

- CAUTION: Static discharge will cause damage to equipment. Always ground yourself with a wrist grounding strap when handling electronics to prevent static discharge.**
- Before removing or inserting any hardware on the controller, **copy down all configuration parameters**. Also, **replacing the battery, EPROM or MCU Board will erase parameter settings** and they will need to be reset.
- For all hardware adjustments, **perform steps 1, 2 and 3**.
- Follow the guide and complete any additional steps as required by your particular application.
- Complete** your hardware adjustments with **steps 15, 16, 17, 18, 19 & 20**.

EQUIPMENT

To make any hardware changes to the units, you will need the following equipment:

- Wrist grounding strap
- Small flat blade screwdriver
- I.C. Extractor (if changing the EPROM)
- Phillips screwdriver (#2)
- Wire cutters

INSTRUCTIONS

To Disassemble the Unit

For any hardware modifications, disassemble the unit.

1. With power off, loosen four captive front screws with a Phillips screwdriver. Remove the four screws.

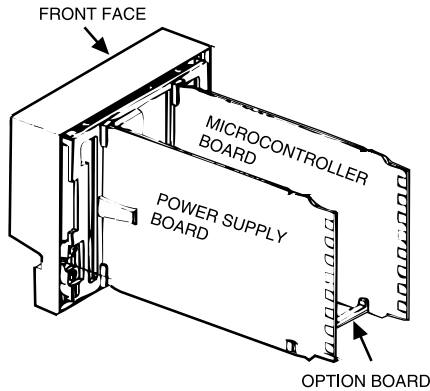

Figure 1
Location of Printed Circuit Boards for Hardware Configuration

2. Slide the chassis out of the case by pulling on front face plate assembly at the bezel (see **Figure 1**).

3. Locate the retention clips holding the front face assembly to the rest of the chassis. Pry apart these retention clips gently with a screwdriver to separate the printed circuit board group from the front face assembly (Photo 3). Take care not to break the clips or scratch the circuit board.

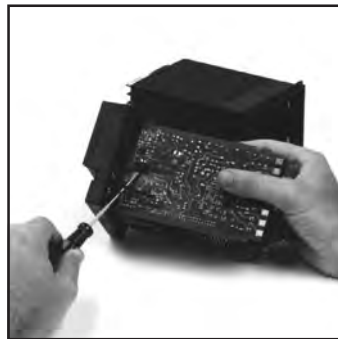

Photo 3. Pry Clips

The Microcontroller Board and Power Supply Board remain attached to the Operator Interface Assembly by wired connectors.

4. The Microcontroller and Power Supply board are attached to either side of the Option board by male/female pin connectors. Use a gentle rocking motion and carefully apply pressure in a uniform direction to separate

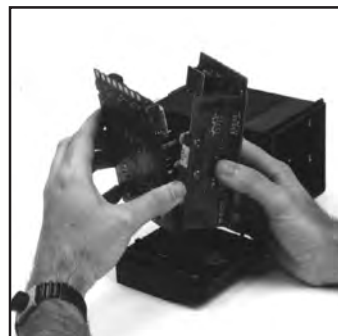

Photo 4. Separate Boards

one of the larger two boards from the Option Board (Photo 4). Be careful not to bend the connector pins. Separate the other board in the same manner.

Figure 2 (opposite page) shows the Microcontroller Board, Option Board and Power Supply Board.

To Add or Change Output Modules

The 500 Series units have provisions for four output modules. The units come factory configured with specified modules installed in appropriate locations. You can make field modifications by properly removing and/or adding the modules into the appropriate sockets.

Three of the output sockets are located on the Power Supply Circuit Board. A fourth output socket is located on the Option Board (refer to **Figure 2**).

5. A retention plate and tie wrap hold Output modules 1, 2, and 3 (on the Power Supply board) firmly in place. To remove the retention plate, snip the tie wrap with wire cutters (Photo 5).

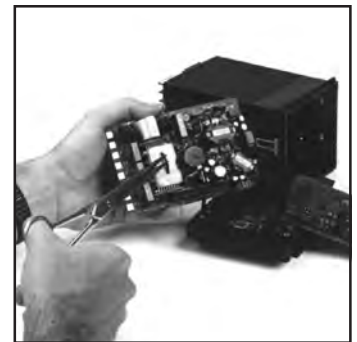

Photo 5.

Remove Retention Plate

CAUTION: Always snip the tie wrap on top of the Retention Plate, as shown in photo 5, to prevent damage to the surface mount components.

6. A disposable tie wrap holds Output module 4 (on the Option board) in place. To remove the module, snip the tie wrap (Photo 6).

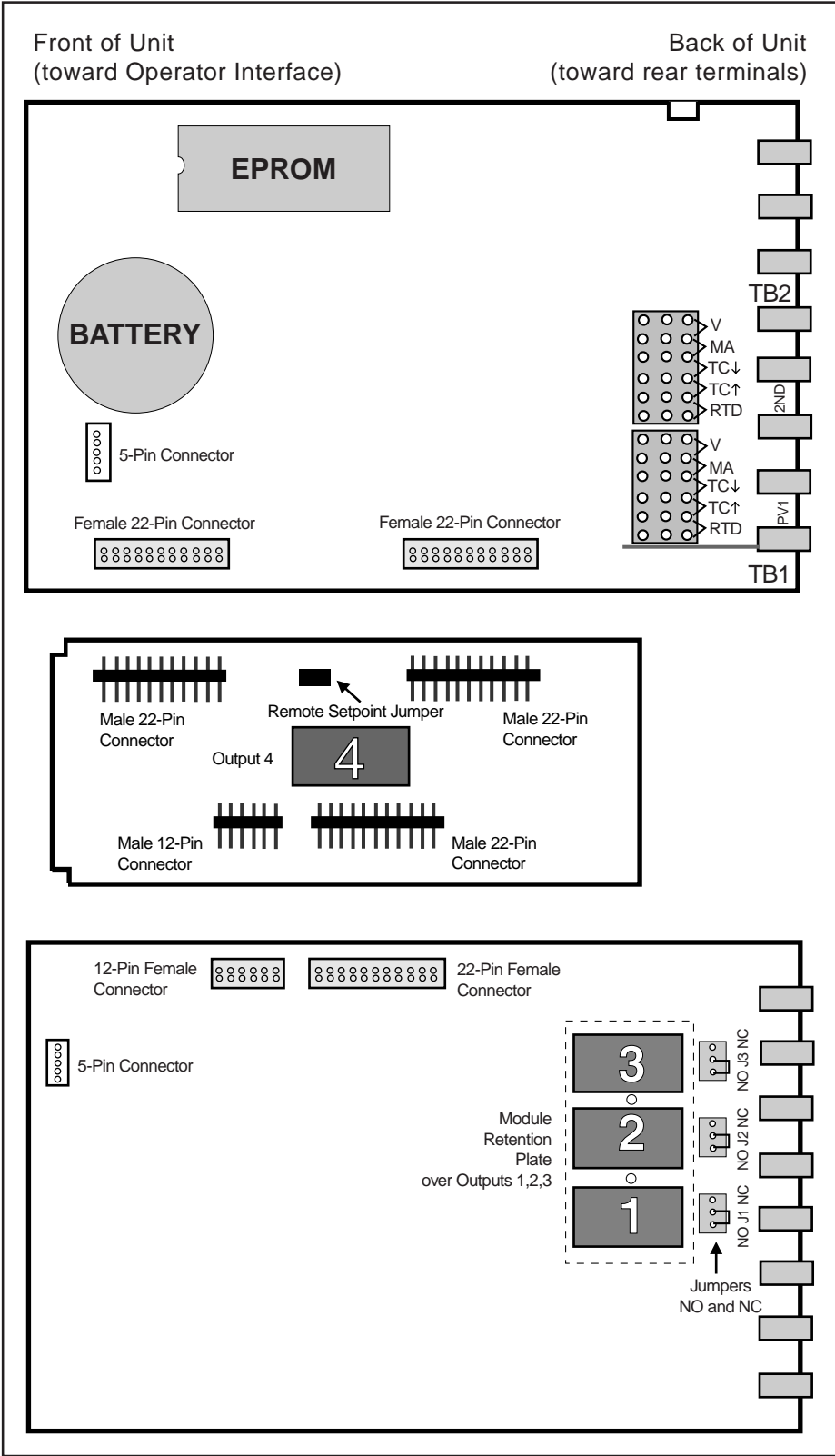

Photo 6.

Snip Tie Wrap on Mod. 4

7. Inspect each module before installation to make sure the pins are straight. Align the pins with the socket holes and carefully insert the module. Press down on the module to seat it firmly on the board.

Installation



NOTE:
If you replace the EPROM chip, you must align the notch facing the front of the unit.

NOTE:
The 5- and 22-Pin connectors on the boards are all keyed so they will only align one correct way.

Figure 2
Microcontroller Board,
Option Board, and
Power Supply Board

8. Replace tie wraps for the Retention Plate and for Output Module 4 with new ones.

Failure to use these devices may result in a loosening of the module and eventual failure. If you ordered a module separately, it should have come with a tie wrap. An extra set of tie wraps is available by ordering Part #535-665.

Note: For greatest accuracy, milliamp modules added for retransmission must be calibrated per instructions in Operator's Manual.

To Change the Option Board

9. (See Photos 3 and 4) Replace the existing Option board with the NEW one.

Note: When adding Option board for 5 digital inputs, associated screw terminal in the rear terminal block must be installed. (See information on page 1 for ordering a Screw Kit.)

To Change the Power Supply or Microcontroller (CPU) Board

10. For the Microcontroller Board, disconnect the 5-pin female connector that wires it to the Display Assembly. Reattach the connector to the new board. You can only orient the connector one way.
For the Power Supply Board, disconnect the 5-pin female connector that wires it to the Display Assembly. Reattach the connector to the new board. You can only orient the connector one way.

To Change the Display Assembly

11. Disconnect the 5-pin female connector that wires the Microcontroller Board to the Display Assembly. Disconnect the 5-pin female connector that wires the Power Supply Board to the Display Assembly.
12. Attach the new Display Assembly to the boards at the appropriate connectors.

CAUTION

Static discharge will cause damage to equipment. Always ground yourself with a wrist grounding strap when handling electronics to prevent static discharge.

CAUTION

Do not scratch the boards or bend the pins of the connectors.

To Change the EPROM

13. The EPROM is located on the Microcontroller Circuit board (**Figure 2**). It has a white label that list the part number and software revision level. Use an I.C. Extractor to carefully remove the EPROM. If you do not have an I.C. extractor, gently use a small flat blade screwdriver to pry up the EPROM. DO NOT bend the EPROM legs.
14. Carefully insert the new EPROM. To position correctly, match the notched end of the EPROM to the markings on the board. The notched end will face towards the display. Make sure all pins are in the socket.

To Reassemble the Unit

15. (See **Figure 2**) Align the connector pins on the Option Board with the connector sockets on the Microcontroller and Power Supply boards. Squeeze them together, making certain all three are properly seated against one another. Check along the side edges for gaps. Make sure the connector is properly aligned. Also, check that the cable assemblies are not pinched.
16. (See **Figure 2**) Align the board assembly with the front face assembly, with the Option board at the bottom (see **Figure 1**). Reinstall the retention clips. Align the boards into the slots of the front face assembly and the clips will snap into place.
17. When you are ready to reassemble the unit, align the boards in the chassis with the case's top and bottom grooves. Press firmly to slide the chassis into the case. If you have difficulty, check that you have properly oriented the chassis, and there are no screws interfering with the case.
18. Carefully insert and align screws. Tighten them until the bezel is seated firmly against the gasket. DO NOT OVERTIGHTEN.
19. If may be necessary to re-configure the software features of your controller or station. Please refer to your User's Manual.
20. To maintain NEMA 4X Rating, you may need new mounting gaskets, order part #535-662. Refer to your user's manual.

RETURN PROCEDURES

To return equipment to Moore Industries for repair, follow these four steps:

1. Call Moore Industries and request a Returned Material Authorization (RMA) number.

Warranty Repair –

If you are unsure if your unit is still under warranty, we can use the unit's serial number to verify the warranty status for you over the phone. Be sure to include the RMA number on all documentation.

Non-Warranty Repair –

If your unit is out of warranty, be prepared to give us a Purchase Order number when you call. In most cases, we will be able to quote you the repair costs at that time. The repair price you are quoted will be a "Not To Exceed" price, which means that the actual repair costs may be less than the quote. Be sure to include the RMA number on all documentation.

2. Provide us with the following documentation:
 - a) A note listing the symptoms that indicate the unit needs repair
 - b) Complete shipping information for return of the equipment after repair
 - c) The name and phone number of the person to contact if questions arise at the factory
3. Use sufficient packing material and carefully pack the equipment in a sturdy shipping container.
4. Ship the equipment to the Moore Industries location nearest you.

The returned equipment will be inspected and tested at the factory. A Moore Industries representative will contact the person designated on your documentation if more information is needed. The repaired equipment, or its replacement, will be returned to you in accordance with the shipping instructions furnished in your documentation.

WARRANTY DISCLAIMER

THE COMPANY MAKES NO EXPRESS, IMPLIED OR STATUTORY WARRANTIES (INCLUDING ANY WARRANTY OF MERCHANTABILITY OR OF FITNESS FOR A PARTICULAR PURPOSE) WITH RESPECT TO ANY GOODS OR SERVICES SOLD BY THE COMPANY. THE COMPANY DISCLAIMS ALL WARRANTIES ARISING FROM ANY COURSE OF DEALING OR TRADE USAGE, AND ANY BUYER OF GOODS OR SERVICES FROM THE COMPANY ACKNOWLEDGES THAT THERE ARE NO WARRANTIES IMPLIED BY CUSTOM OR USAGE IN THE TRADE OF THE BUYER AND OF THE COMPANY, AND THAT ANY PRIOR DEALINGS OF THE BUYER WITH THE COMPANY DO NOT IMPLY THAT THE COMPANY WARRANTS THE GOODS OR SERVICES IN ANY WAY.

ANY BUYER OF GOODS OR SERVICES FROM THE COMPANY AGREES WITH THE COMPANY THAT THE SOLE AND EXCLUSIVE REMEDIES FOR BREACH OF ANY WARRANTY CONCERNING THE GOODS OR SERVICES SHALL BE FOR THE COMPANY, AT ITS OPTION, TO REPAIR OR REPLACE THE GOODS OR SERVICES OR REFUND THE PURCHASE PRICE. THE COMPANY SHALL IN NO EVENT BE LIABLE FOR ANY CONSEQUENTIAL OR INCIDENTAL DAMAGES EVEN IF THE COMPANY FAILS IN ANY ATTEMPT TO REMEDY DEFECTS IN THE GOODS OR SERVICES, BUT IN SUCH CASE THE BUYER SHALL BE ENTITLED TO NO MORE THAN A REFUND OF ALL MONIES PAID TO THE COMPANY BY THE BUYER FOR PURCHASE OF THE GOODS OR SERVICES.

ANY CAUSE OF ACTION FOR BREACH OF ANY WARRANTY BY THE COMPANY SHALL BE BARRED UNLESS THE COMPANY RECEIVES FROM THE BUYER A WRITTEN NOTICE OF THE ALLEGED DEFECT OR BREACH WITHIN TEN DAYS FROM THE EARLIEST DATE ON WHICH THE BUYER COULD REASONABLY HAVE DISCOVERED THE ALLEGED DEFECT OR BREACH, AND NO ACTION FOR THE BREACH OF ANY WARRANTY SHALL BE COMMENCED BY THE BUYER ANY LATER THAN TWELVE MONTHS FROM THE EARLIEST DATE ON WHICH THE BUYER COULD REASONABLY HAVE DISCOVERED THE ALLEGED DEFECT OR BREACH.

RETURN POLICY

For a period of thirty-six (36) months from the date of shipment, and under normal conditions of use and service, Moore Industries ("The Company") will at its option replace, repair or refund the purchase price for any of its manufactured products found, upon return to the Company (transportation charges prepaid and otherwise in accordance with the return procedures established by The Company), to be defective in material or workmanship. This policy extends to the original Buyer only and not to Buyer's customers or the users of Buyer's products, unless Buyer is an engineering contractor in which case the policy shall extend to Buyer's immediate customer only. This policy shall not apply if the product has been subject to alteration, misuse, accident, neglect or improper application, installation, or operation. THE COMPANY SHALL IN NO EVENT BE LIABLE FOR ANY INCIDENTAL OR CONSEQUENTIAL DAMAGES.



United States • info@miinet.com
Tel: (818) 894-7111 • FAX: (818) 891-2816
Australia • sales@mooreind.com.au
Tel: (02) 8536-7200 • FAX: (02) 9525-7296

Belgium • info@mooreind.be
Tel: 03/448.10.18 • FAX: 03/440.17.97
The Netherlands • sales@mooreind.nl
Tel: (0)344-617971 • FAX: (0)344-615920

China • sales@mooreind.sh.cn
Tel: 86-21-62481120 • FAX: 86-21-62490635
United Kingdom • sales@mooreind.com
Tel: 01293 514488 • FAX: 01293 387752

The Interface Solution Experts • www.miinet.com

October 2023

Purpose

This supplement is to address the updated Micro Controller Board with removable Lithium Battery. Older models required to be serviced by Moore Industries to replace Lithium Battery which was soldered directly on the board, this is an inconvenience and has been resolved with a Micro Controller Board that has a replaceable Lithium Battery slot.

You can order replacement directly from Moore Industries using this part number 800-867-52 or an equivalent CR2450 3V Coin Cell Lithium Battery.

To replace battery in your 500 Series unit follow previous instructions found in M500 V6. Use a flat head screwdriver to release battery and replace.

Figure 1. Removable Lithium Battery

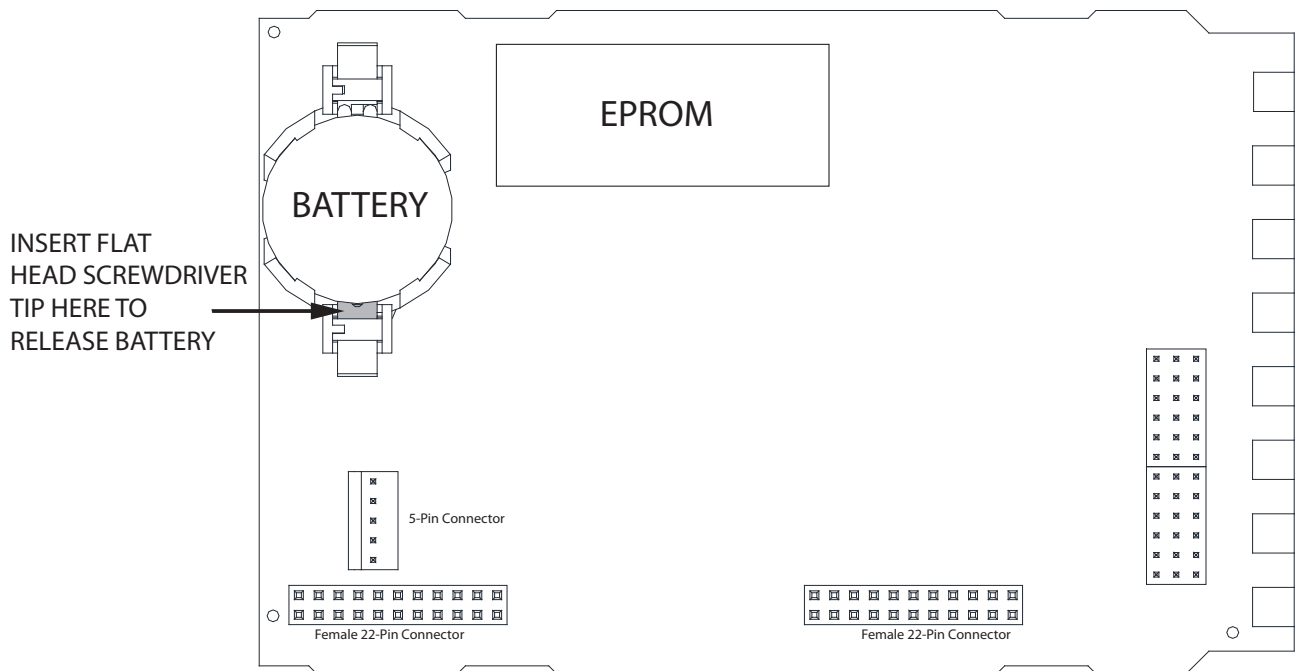

RETURN PROCEDURES

To return equipment to Moore Industries for repair, follow these four steps:

1. Call Moore Industries and request a Returned Material Authorization (RMA) number.

Warranty Repair –

If you are unsure if your unit is still under warranty, we can use the unit's serial number to verify the warranty status for you over the phone. Be sure to include the RMA number on all documentation.

Non-Warranty Repair –

If your unit is out of warranty, be prepared to give us a Purchase Order number when you call. In most cases, we will be able to quote you the repair costs at that time. The repair price you are quoted will be a "Not To Exceed" price, which means that the actual repair costs may be less than the quote. Be sure to include the RMA number on all documentation.

2. Provide us with the following documentation:
 - a) A note listing the symptoms that indicate the unit needs repair
 - b) Complete shipping information for return of the equipment after repair
 - c) The name and phone number of the person to contact if questions arise at the factory
3. Use sufficient packing material and carefully pack the equipment in a sturdy shipping container.
4. Ship the equipment to the Moore Industries location nearest you.

The returned equipment will be inspected and tested at the factory. A Moore Industries representative will contact the person designated on your documentation if more information is needed. The repaired equipment, or its replacement, will be returned to you in accordance with the shipping instructions furnished in your documentation.

WARRANTY DISCLAIMER

THE COMPANY MAKES NO EXPRESS, IMPLIED OR STATUTORY WARRANTIES (INCLUDING ANY WARRANTY OF MERCHANTABILITY OR OF FITNESS FOR A PARTICULAR PURPOSE) WITH RESPECT TO ANY GOODS OR SERVICES SOLD BY THE COMPANY. THE COMPANY DISCLAIMS ALL WARRANTIES ARISING FROM ANY COURSE OF DEALING OR TRADE USAGE, AND ANY BUYER OF GOODS OR SERVICES FROM THE COMPANY ACKNOWLEDGES THAT THERE ARE NO WARRANTIES IMPLIED BY CUSTOM OR USAGE IN THE TRADE OF THE BUYER AND OF THE COMPANY, AND THAT ANY PRIOR DEALINGS OF THE BUYER WITH THE COMPANY DO NOT IMPLY THAT THE COMPANY WARRANTS THE GOODS OR SERVICES IN ANY WAY.

ANY BUYER OF GOODS OR SERVICES FROM THE COMPANY AGREES WITH THE COMPANY THAT THE SOLE AND EXCLUSIVE REMEDIES FOR BREACH OF ANY WARRANTY CONCERNING THE GOODS OR SERVICES SHALL BE FOR THE COMPANY, AT ITS OPTION, TO REPAIR OR REPLACE THE GOODS OR SERVICES OR REFUND THE PURCHASE PRICE. THE COMPANY SHALL IN NO EVENT BE LIABLE FOR ANY CONSEQUENTIAL OR INCIDENTAL DAMAGES EVEN IF THE COMPANY FAILS IN ANY ATTEMPT TO REMEDY DEFECTS IN THE GOODS OR SERVICES, BUT IN SUCH CASE THE BUYER SHALL BE ENTITLED TO NO MORE THAN A REFUND OF ALL MONIES PAID TO THE COMPANY BY THE BUYER FOR PURCHASE OF THE GOODS OR SERVICES.

ANY CAUSE OF ACTION FOR BREACH OF ANY WARRANTY BY THE COMPANY SHALL BE BARRED UNLESS THE COMPANY RECEIVES FROM THE BUYER A WRITTEN NOTICE OF THE ALLEGED DEFECT OR BREACH WITHIN TEN DAYS FROM THE EARLIEST DATE ON WHICH THE BUYER COULD REASONABLY HAVE DISCOVERED THE ALLEGED DEFECT OR BREACH, AND NO ACTION FOR THE BREACH OF ANY WARRANTY SHALL BE COMMENCED BY THE BUYER ANY LATER THAN TWELVE MONTHS FROM THE EARLIEST DATE ON WHICH THE BUYER COULD REASONABLY HAVE DISCOVERED THE ALLEGED DEFECT OR BREACH.

RETURN POLICY

For a period of thirty-six (36) months from the date of shipment, and under normal conditions of use and service, Moore Industries ("The Company") will at its option replace, repair or refund the purchase price for any of its manufactured products found, upon return to the Company (transportation charges prepaid and otherwise in accordance with the return procedures established by The Company), to be defective in material or workmanship. This policy extends to the original Buyer only and not to Buyer's customers or the users of Buyer's products, unless Buyer is an engineering contractor in which case the policy shall extend to Buyer's immediate customer only. This policy shall not apply if the product has been subject to alteration, misuse, accident, neglect or improper application, installation, or operation. THE COMPANY SHALL IN NO EVENT BE LIABLE FOR ANY INCIDENTAL OR CONSEQUENTIAL DAMAGES.



United States • info@miinet.com
Tel: (818) 894-7111 • FAX: (818) 891-2816
Australia • sales@mooreind.com.au
Tel: (02) 8536-7200 • FAX: (02) 9525-7296

Belgium • info@mooreind.be
Tel: 03/448.10.18 • FAX: 03/440.17.97
The Netherlands • sales@mooreind.nl
Tel: (0)344-617971 • FAX: (0)344-615920

China • sales@mooreind.sh.cn
Tel: 86-21-62481120 • FAX: 86-21-62490635
United Kingdom • sales@mooreind.com
Tel: 01293 514488 • FAX: 01293 387752

The Interface Solution Experts • www.miinet.com